



 **Beta**
C45PRO2.0

INTEGRATED WORKSHOP EQUIPMENT

 **Beta**
RS0502.0





IMAGINE A PLACE where **ORDER** and **FUNCTIONALITY** merge in perfect **HARMONY**: this is what Beta's integrated workshop equipment can offer.

Designed to cater for every professional's needs, the **modular workshop equipment** ranges developed by Beta turn any space into an efficient, well-organised work environment, regardless of its dimensions.

Not only does Beta's integrated workshop equipment maximise productivity, but it creates an environment which epitomises skills and passion for one's job as well.



For those seeking a simple, flexible solution, with an excellent quality/price ratio, for their workshops or workspaces



For those wishing to match design, functionality and durability



For those aiming for excellence and exclusiveness – for example, in motorsports pits. Discover it online!



BETA'S THREE WORKSHOP EQUIPMENT RANGES STAND OUT FOR THEIR QUALITY, AS TYPICAL OF BETA'S PRODUCTS, WHICH ENSURES RELIABLE, LASTING SOLUTIONS

INDEX



Introduction	2-3
Comprehensive combinations	4÷17
Combinations with 46-cm-deep worktops and extension kits	30÷32
Worktops	19
Mobile roller cabs	20
Fixed modules	21÷24
Perforated panels and wall units	25-26
Corners	27
Cabinets	28-29
Assortments	33; 66-67
Accessories	34; 68÷71
Reels	64-65
3D configurator	72
Customised modules	73



Workshop equipment C45PRO 2.0 is ideal for those seeking a simple, flexible solution, with an excellent quality/price ratio, for their workshops or workspaces.



ASSEMBLY
Watch the assembly
videos



COMBINATIONS

Professionals can opt for one of the numerous preassembled combinations or design their workplaces from scratch, adding any of the available parts and accessories to them.

The **61,5-cm-deep** worktop is available in both **stainless steel coated MDF** and **MULTI-PLY WOOD**.

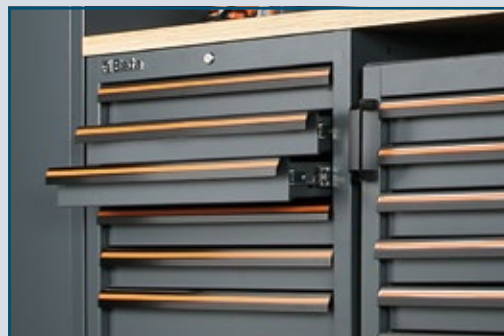
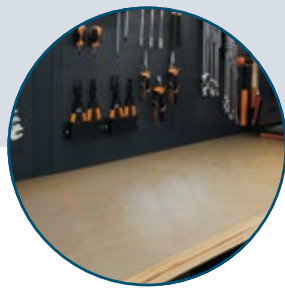
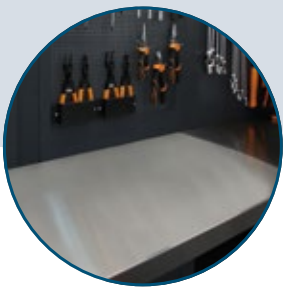

Aluminium handles



Vertically adjustable feet

30

Three configurations with 46-cm-deep worktops made from stainless steel coated MDF are also available, for small spaces, or for those wishing to supplement a C45PRO workshop equipment combination with a solution in the same size

32

Some convenient extension kits are available for anyone who already has a C45PRO workshop equipment combination and would like to change to version 2.0

46-cm-deep worktop

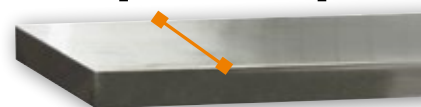

C45PRO 2.0 D

Beta
C45PRO20



2000 mm
645 mm
3718+3038 mm

Combination comprising the following:

- 1 fixed module with 7 drawers (C45PRO 2.0 M7)
- 1 mobile roller cab with 7 drawers (C45PRO 2.0 C7)
- 1 fixed service module (C45PRO 2.0 MS)
- 1 fixed module with 5 drawers (C45PRO 2.0 M5)
- 1 fixed two-door module (C45PRO 2.0 MA)
- 5 perforated tool panels (C45PRO 2.0 PF)
- 5 wall-mounted cabinets (C45PRO 2.0 PM)
- 7 wall brackets, wide type (C45PRO 2.0 SL)
- 2 wall brackets, narrow type (C45PRO 2.0 SS)
- 2 single-door cabinets (C45PRO 2.0 AS1)

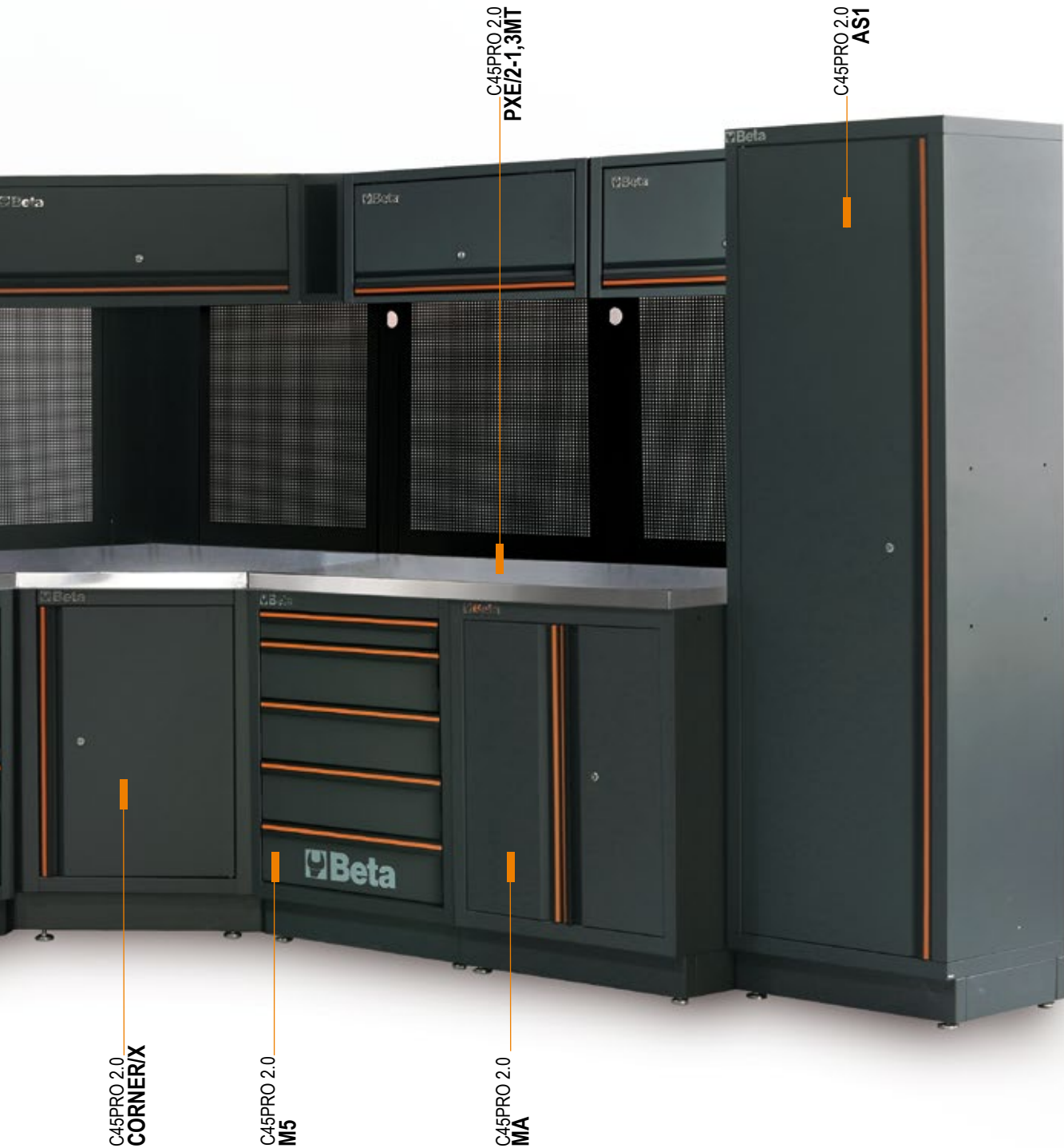

C45PRO 2.0 DX

045002031

- 1 **stainless steel coated MDF** worktop, dimensions 2,040x615 mm (C45PRO 2.0 PXE/3-2.0MT)
- 1 **stainless steel coated MDF** worktop, dimensions 1,360x615 mm (C45PRO 2.0 PXE/2-1,3MT)
- 1 self-supporting complete corner with **stainless steel coated MDF** worktop (C45PRO 2.0 CORNER/X)

640 kg



C45PRO 2.0 DW

045002032

- 1 **multi-ply wood** worktop, dimensions 2,040x615 mm (C45PRO 2.0 PWE/3-2.0MT)
- 1 **multi-ply wood** worktop, dimensions 1,360x615 mm (C45PRO 2.0 PWE/2-1.3MT)
- 1 self-supporting complete corner with **multi-ply wood** worktop (C45PRO 2.0 CORNER/W)

606 kg



C45PRO 2.0 F



C45PRO 2.0
PM

C45PRO 2.0
PFE

C45PRO 2.0
PF

C45PRO 2.0
PXE/3-2,0MT

2000 mm
645 mm
3718+3038 mm



C45PRO 2.0
MA

C45PRO 2.0
C7

C45PRO 2.0
M7

Combination comprising the following:

- 1 fixed two-door module (C45PRO 2.0 MA)
- 1 mobile roller cab with 7 drawers (C45PRO 2.0 C7)
- 1 fixed module with 7 drawers (C45PRO 2.0 M7)
- 1 fixed module with 2 built-in reels (C45PRO 2.0 ACT)
- 1 fixed service module (C45PRO 2.0 MS)
- 2 perforated tool panels (C45PRO 2.0 PF)
- 1 perforated tool panel, can be fitted with a power socket (not included) (C45PRO 2.0 PFE)
- 3 wall-mounted cabinets (C45PRO 2.0 PM)
- 1 tool wall system with aluminium shutter (C45PRO 2.0 PAS)

- 6 wall brackets, wide type (C45PRO 2.0 SL)
- 4 wall brackets, narrow type (C45PRO 2.0 SS)
- 2 single-door cabinets (C45PRO 2.0 AS1)

INCLUDED



1900S 8x10



1844 15-H05



C45PRO 2.0 FX

045002035

- 1 **stainless steel coated MDF** worktop, dimensions 2,040x615 mm (C45PRO 2.0 PXE/3-2,0MT)
- 1 **stainless steel coated MDF** worktop, dimensions 1,360x615 mm (C45PRO 2.0 PXE/2-1.3MT)
- 1 self-supporting complete corner with **stainless steel coated MDF** worktop (C45PRO 2.0 CORNER/X)

658 kg



C45PRO 2.0 FW

045002045

- 1 **multi-ply wood** worktop, dimensions 2,040x615 mm (C45PRO 2.0 PWE/3-2.0MT)
- 1 **multi-ply wood** worktop, dimensions 1,60x615 mm (C45PRO 2.0 PWE/2-1.3MT)
- 1 self-supporting complete corner with **multi-ply wood** worktop (C45PRO 2.0 CORNER/W)

625 kg



C45PRO 2.0 G



2000 mm
645 mm
3718+2358 mm

Combination comprising the following:

- 1 fixed module with **2 built-in reels** (C45PRO 2.0 ACT)
- 1 mobile roller cab with 7 drawers (C45PRO 2.0 C7)
- 1 fixed module with 7 drawers (C45PRO 2.0 M7)
- 1 fixed two-door module (C45PRO 2.0 MA)
- 1 perforated tool panel (C45PRO 2.0 PF)
- 1 perforated tool panel, can be fitted with a power socket (not included) (C45PRO 2.0 PFE)
- 2 wall-mounted cabinets (C45PRO 2.0 PM)
- 1 tool wall system with aluminium shutter (C45PRO 2.0 PAS)
- 5 wall brackets, wide type (C45PRO 2.0 SL)
- 4 wall brackets, narrow type (C45PRO 2.0 SS)
- 2 single-door cabinets (C45PRO 2.0 AS1)

INCLUDED



1900S 8x10



1844 15-H05



C45PRO 2.0 GX

045002036

- 1 **stainless steel coated MDF** worktop, dimensions 2,040x615 mm (C45PRO 2.0 PXE/3-2.0MT)
- 1 **stainless steel coated MDF** worktop, dimensions 680x615 mm (C45PRO 2.0 PXE/1-0.7MT)
- 1 self-supporting complete corner with **stainless steel coated MDF** worktop (C45PRO 2.0 CORNER/X)

554 kg



C45PRO 2.0 GW

045002037

- 1 **multi-ply wood** worktop, dimensions 2,040x615 mm (C45PRO 2.0 PWE/3-2.0MT)
- 1 **multi-ply wood** worktop, dimensions 680x615 mm (C45PRO 2.0 PWE/1-0.7MT)
- 1 self-supporting complete corner with **multi-ply wood** worktop (C45PRO 2.0 CORNER/W)

551 kg



C45PRO 2.0



C45PRO 2.0
AS2

C45PRO 2.0
PXE/3-2,0MT

C45PRO 2.0
PF

C45PRO 2.0
PM

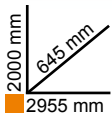

C45PRO 2.0
M5

C45PRO 2.0
C7

C45PRO 2.0
MS

Combination comprising the following:

- Fixed module with 5 drawers (C45PRO 2.0 M5)
- Mobile roller cab with 7 drawers (C45PRO 2.0 C7)
- Fixed service module (C45PRO 2.0 MS)
- 3 perforated tool panels (C45PRO 2.0 PF)
- 3 wall-mounted cabinets (C45PRO 2.0 PM)
- 3 wall brackets, wide type (C45PRO 2.0 SL)
- 1 wall bracket, narrow type (C45PRO 2.0 SS)
- Two-door cabinet (C45PRO 2.0 AS2)

C45PRO 2.0 X

045002001

- **Stainless steel coated MDF** worktop, dimensions 2,040x615 mm (C45PRO 2.0 PXE/3-2,0MT)

334 kg



C45PRO 2.0 W

045002002

- **Multi-ply wood** worktop, dimensions 2,040x615 mm (C45PRO 2.0 PWE/3-2,0MT)

318 kg





Combination comprising the following:

- 1 fixed module with 2 built-in reels (C45PRO 2.0 ACT)
- 1 mobile roller cab with 7 drawers (C45PRO 2.0 C7)
- 1 fixed module with 4 drawers (C45PRO 2.0 M4)
- 3 wall-mounted cabinets (C45PRO 2.0 PM)
- 3 perforated tool panels (C45PRO 2.0 PF)
- 3 wall brackets, wide type (C45PRO 2.0 SL)
- 1 wall bracket, narrow type (C45PRO 2.0 SS)
- 1 two-door cabinet (C45PRO 2.0 AS2)

INCLUDED



1900S 8x10



1844 15-H05

C45PRO 2.0 HX

045002038

- **Stainless steel coated MDF** worktop, dimensions 2,040x615 mm (C45PRO 2.0 PXE/3-2,0MT)



333 kg

C45PRO 2.0 HW

045002039

- **Multi-ply wood** worktop, dimensions 2,040x615 mm (C45PRO 2.0 PWE/3-2,0MT)



318 kg

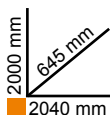
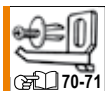

Combination comprising the following:

- Fixed service module (C45PRO 2.0 MS)
- Fixed module with 7 drawers (C45PRO 2.0 M7)
- Fixed two-door module (C45PRO 2.0 MA)
- 3 wall-mounted cabinets (C45PRO 2.0 PM)
- 3 perforated tool panels (C45PRO 2.0 PF)
- 2 wall brackets, wide type (C45PRO 2.0 SL)
- 2 wall brackets, narrow type (C45PRO 2.0 SS)

C45PRO 2.0 AX

045002003

- **Stainless steel coated MDF** worktop, dimensions 2,040x615 mm (C45PRO 2.0 PXE/3-2.0MT)



234,5 kg

C45PRO 2.0 AW

045002004

- **Multi-ply wood** worktop, dimensions 2,040x615 mm (C45PRO 2.0 PWE/3-2.0MT)



219 kg

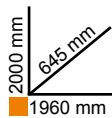

Combination comprising the following:

- Fixed module with 5 drawers (C45PRO M5)
- Fixed two-door module (C45PRO MA)
- 2 wall-mounted cabinets (C45PRO PM)
- 2 perforated tool panels (C45PRO PF)
- 2 wall brackets, wide type (C45PRO SL)
- 1 wall bracket, narrow type (C45PRO SS)
- Single-door cabinet (C45PRO AS1)

C45PRO 2.0 BX

04500201

- Stainless steel coated MDF worktop, dimensions 1,360x463mm (C45PX/2-1.3MT)

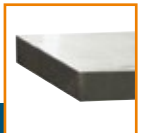

206 kg

C45PRO 2.0 BW

04500202

- Multi-ply wood worktop, dimensions 1,360x615 mm (C45PRO 2.0 PWE/2-1.3MT)



196 kg

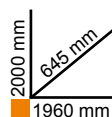
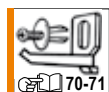

Combination comprising the following:

- Fixed service module (C45PRO 2.0 MS)
- Fixed module with 7 drawers (C45PRO 2.0 M7)
- 2 wall-mounted cabinets (C45PRO 2.0 PM)
- 2 perforated tool panels (C45PRO 2.0 PF)
- 2 wall brackets, wide type (C45PRO 2.0 SL)
- 1 wall bracket, narrow type (C45PRO 2.0 SS)
- Single-door cabinet (C45PRO 2.0 AS1)

C45PRO 2.0 CX

045002023

- **Stainless steel coated MDF** worktop, dimensions 1,360x615 mm (C45PRO 2.0 PXE/2-1.3MT)



225 kg

C45PRO 2.0 CW

045002024

- **Multi-ply wood** worktop, dimensions 1,360x615 mm (C45PRO 2.0 PWE/2-1.3MT)



215 kg

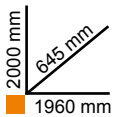

Combination comprising the following:

- 2 perforated tool panels (C45PRO 2.0 PF)
 - 2 wall-mounted cabinets (C45PRO 2.0 PM)
 - 2 wall brackets, wide type (C45PRO 2.0 SL)
 - 1 wall bracket, narrow type (C45PRO 2.0 SS)
 - 1 single-door cabinet (C45PRO 2.0 AS1)
-
- Fixed module with 7 drawers (C45PRO 2.0 M7A):
 - 1 drawer 1.248x406 mm
 - 6 drawers 782x406 mm
 - 5 drawers 65 mm high
 - 1 drawer 145 mm high
 - 1 storage compartment with intermediate shelf and door

C45PRO 2.0 EX

045002033

- Fixed module with 7 drawers and **stainless steel coated MDF** worktop, dimensions 1,360x615 mm (C45PRO 2.0 M7A/X)

203 kg



C45PRO 2.0 EW

045002034

- Fixed module with 7 drawers and **multiply wood** worktop, dimensions 1,360x615 mm (C45PRO 2.0 M7A/W)

193 kg



C45PRO 2.0 BP-1,3

Combination comprising the following:

- Fixed module with 7 drawers (C45PRO 2.0 M7)
- Fixed module with 5 drawers (C45PRO 2.0 M5)
- 2 perforated tool panels (C45PRO 2.0 PF)
- 1 wall bracket, wide type (C45PRO 2.0 SL)
- 2 wall brackets, narrow type (C45PRO 2.0 SS)

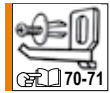
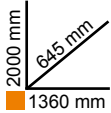

C45PRO 2.0 BP-2,0

Combination comprising the following:

- Fixed module with 7 drawers (C45PRO 2.0 M7)
- Fixed module with 5 drawers (C45PRO 2.0 M5)
- 3 perforated tool panels (C45PRO 2.0 PF)
- 2 wall brackets, wide type (C45PRO 2.0 SL)
- 2 wall brackets, narrow type (C45PRO 2.0 SS)

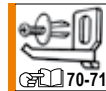
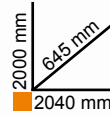

C45PRO 2.0 BPX-1,3

045002041 155 kg

- Stainless steel coated MDF worktop, dimensions 1,360x615 mm (C45PRO 2.0 PXE/2-1.3MT)

C45PRO 2.0 BPX-2,0

045002042 181 kg

- Stainless steel coated MDF worktop, dimensions 2,040x615 mm (C45PRO 2.0 PXE/3-2.0MT)

C45PRO 2.0 BPW-1,3

045002051 145 kg

- Multi-ply wood worktop, dimensions 1,360x615 mm (C45PRO 2.0 PWE/2-1.3MT)

C45PRO 2.0 BPW-2,0

045002052 165 kg

- Multi-ply wood worktop, dimensions 2,040x615 mm (C45PRO 2.0 PWE/3-2.0MT)

C45PRO 2.0 BL

Workbench

- Sheet metal framework
- With vertically adjustable feet
- Can accommodate a vice (1599P/150, to be ordered separately)
- To be used only as an addition to a workshop equipment combination, not as a stand-alone element

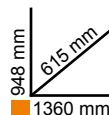

C45PRO 2.0 BLX

045002156

- Worktop (1,360x615 mm) made from stainless steel coated MDF

C45PRO 2.0 BLW

045002157

- Worktop (1,360x615 mm) made from multi-ply wood

C45PRO 2.0 M7A

Fixed module with 7 drawers

- 1 drawer (1,248x406 mm) with ball bearing slides
- 6 drawers (782x406 mm) with ball bearing slides:
 - 5 drawers 65 mm high
 - 1 drawer 145 mm high
- Drawer bases protected by foamed rubber mats
- Front centralized lock
- With vertically adjustable feet
- Can be fitted with thermoformed trays
- 1 storage compartment with intermediate shelf and door, interior dimensions 504x424x597 mm
- Can accommodate a vice (1599P/150, to be ordered separately)



C45PRO 2.0 M7A/X

045002161 81 kg

- Worktop (1,360x615 mm) made from **stainless steel coated MDF**

C45PRO 2.0 M7A/W

045002171 80 kg

- **Multi-ply wood** worktop, 1,360x615 mm

0

h	max
65 mm	25 kg
105 mm	40 kg
145 mm	30 kg

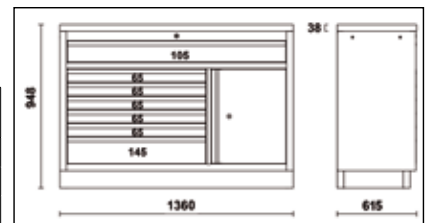

C45PRO 2.0 MWS

Work Station roller cab with 7 drawers and built-in waste bin

- 1 drawer (1248x406 mm) with ball bearing slides
- 6 drawers (782x406 mm) with ball bearing slides:
 - 5 drawers 65 mm high
 - 1 drawer 145 mm high
- Drawer bases protected by foamed rubber mats
- Can be fitted with thermoformed trays
- Storage compartment with intermediate shelf and door, interior dimensions 504x424x597 mm
- Built-in waste bin
- Built-in paper roll compartment
- 4 heavy-duty castors, Ø 150 mm, 2 fixed and 2 steering with brakes
- Front centralised lock
- Can accommodate a vice (1599P/150, to be ordered separately)



C45PRO 2.0 CPF

h	max
65 mm	25 kg
105 mm	40 kg
145 mm	30 kg

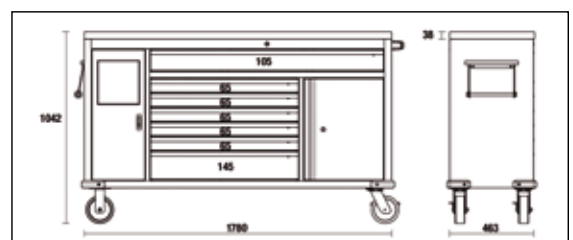

C45PRO 2.0 MWS/X

045000181 126 kg

- Worktop (1680 mm) made of **stainless steel coated MDF**

C45PRO 2.0 MWS/W

045000191 122 kg

- **Multi-ply wood** worktop (1680 mm)

CREATE YOUR CUSTOMISED WORKSHOP FROM SCRATCH

Workspace C45PRO 2.0 can be configured from scratch and catered to satisfy one's requirements, based on a large choice of:

WORKTOP

made from stainless steel coated MDF or multi-ply wood

19



MOBILE ROLLER CABS

20



FIXED MODULE

21÷24

PERFORATED PANELS AND WALL UNITS

25-26



CORNERS

27

CABINET

28-29



ASSORTMENT

33; 66-67

ACCESSORIES

34; 64-65; 68÷71



3D configurator 72

C45PRO 2.0 PXE

Worktop made from stainless steel coated MDF

- Thickness: 38 mm
- Can accommodate a vice (1599P/150, to be ordered separately)
- Complete with 2 spacers and 2 exterior side pads

C45PRO 2.0 PXE/1-0,7MT

045002131

14 kg

680x615x38 mm

C45PRO 2.0 PXE/2-1,3MT

045002133

27 kg

1360x615x38 mm

C45PRO 2.0 PXE/3-2,0MT

045002140

41,5 kg

2040x615x38 mm



C45PRO 2.0 PWE

Worktop made from multi-ply wood

- Thickness: 38 mm
- Can accommodate a vice 1599P/150 (to be ordered separately)
- Complete with 2 spacers and 2 exterior side pads

C45PRO 2.0 PWE/1-0,7MT

045002141

8 kg

680x615x38 mm

C45PRO 2.0 PWE/2-1,3MT

045002143

17 kg

1360x615x38 mm

C45PRO 2.0 PWE/3-2,0MT

045002150

26 kg

2040x615x38 mm



C45PRO 2.0 RB NEW

Shockproof, non-scratch PVC coat, resistant to hydrocarbons, for workshop equipment combination C45PRO 2.0

A must-have for protecting worktops.

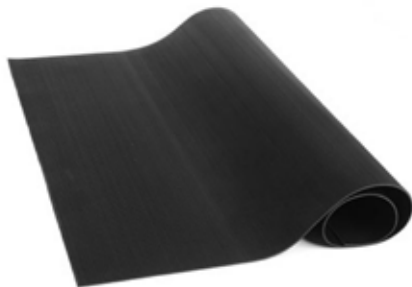

C45PRO 2.0 RB/0,7

045002180

1,5 kg

680x615x2,5 mm

C45PRO 2.0 RB/1,02

045002181

3,7 kg

for corner worktop

1.018x1.018x2,5mm

C45PRO 2.0 RB/1,3

045002182

2,9 kg

1360x615x2,5mm

C45PRO 2.0 RB/2,0

045002183

4,5 kg

2040x615x2,5mm

1599P/150

Parallel bench vices

- Hardened jaws
- Anvil with large lacquered surface
- Square steel base

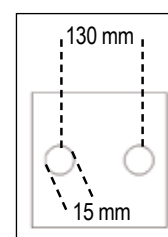
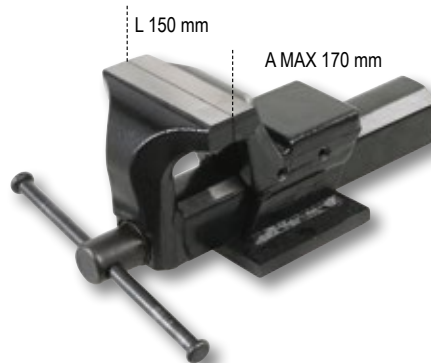

015990050

15,5 kg

Mobile roller cabs

- **ABS worktop with anti-fall edges**
- Drawers (532x406 mm) with ball bearing slides
- 4 swivel castors, Ø 100 mm (2 with brakes)
- Drawer bases protected by foamed rubber mats
- Front centralized lock
- Can be fitted with thermoformed trays
- Handles built into frame for improved ease of handling

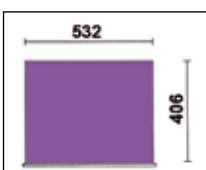

h	max
65 mm	25 kg
145 mm	30 kg

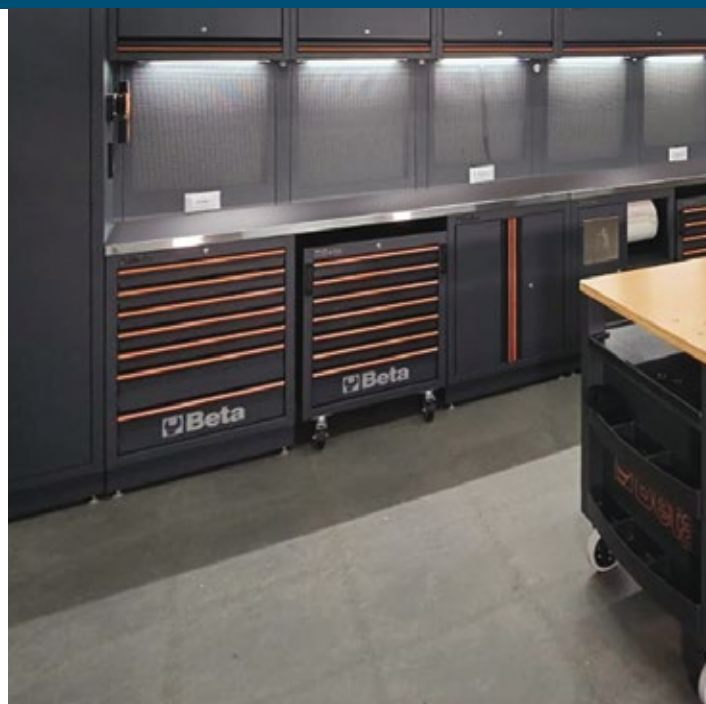

C45PRO 2.0 C5

045000226 46 kg

Mobile roller cab with 5 drawers

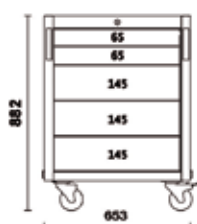

C45PRO 2.0 C7

045000228 50 kg

Mobile roller cab with 7 drawers

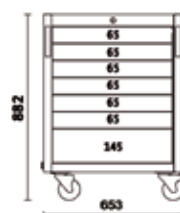

C45PRO 2.0 T3

045000250 19,2 kg

3-tier tool trolley

- 4 swivel castors, Ø 100 mm (one with brake)
- Static load capacity: 200 kg (distributed over 3 shelves)





Fixed module

- 4 drawers (566x406 mm) with ball bearing slides
- Drawer bases protected by foamed rubber mats
- Front centralized lock
- With vertically adjustable feet
- Can be fitted with thermoformed trays

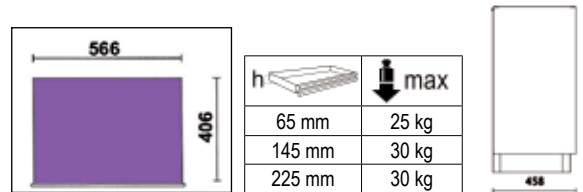

C45PRO 2.0 M4

045000234 46,7 kg

Fixed module with 4 drawers

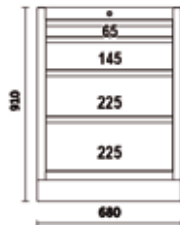

C45PRO 2.0 M5

045000235 49,3 kg

Fixed module with 5 drawers

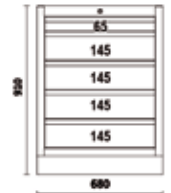

C45PRO 2.0 M7

045000237 54,3 kg

Fixed module with 7 drawers

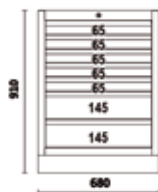

C45PRO 2.0 M8

045000238 56,8 kg

Fixed module with 8 drawers

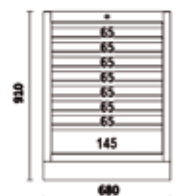

C45PRO 2.0 TC

045000249 40,9 kg

Fixed reel module with 3 drawers, empty

- 3 drawers (566x406 mm) with ball bearing slides
- Drawer bases protected by foamed rubber mats
- Front centralized lock
- With vertically adjustable feet

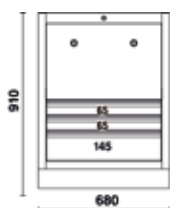

C45PRO 2.0 ACT

045000247 50,7 kg

Fixed module with 3 drawers and 2 built-in reels

- 3 drawers (566x406 mm) with ball bearing slides
- Drawer bases protected by foamed rubber mats
- Front centralized lock
- With vertically adjustable feet

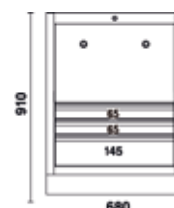

Can accommodate 2 reels, to be chosen from the following (to be ordered seperately):

- 2 compressed air or cold water hose reels, 8 mm, length 10 m item 1900S 8x10
- 2 cable reels, to be chosen from the following items: 1843 15-H05, 1844 10-H05, 1844 15-H05, 1844 15-H07, 1845 12-H05, 1846 10-H05, 1846 10-H07 and 1846 15-H05
- 1 compressed air or cold water hose reel, 8 mm, length 10 m item 1900S 8x10 and 1 cable reel, to be chosen from the above-mentioned items

INCLUDED



1900S 8X10



1844 15-H05

C45PRO 2.0 MA

045000232 29,4 kg

Fixed two-door module

- With lock
- Vertically adjustable interior shelf
- Interior dimensions: 670x420 mm
- With vertically adjustable feet



C45PRO 2.0 MS

045000239 37 kg

fixed service module

- Built-in waste bin
- Paper roll compartment
- With vertically adjustable feet



C45PRO 2.0 MRE

045000242 57 kg

Fixed module for charging power tools

- Pull-out side compartment with ball bearing slides, for storing power tools
- Fixed side compartment with door and lock for storing chargers and batteries, equipped with:
 - vertically adjustable shelf;
 - rubber-protected cable bushings;
 - ventilation slots;
- 1 drawer (256x400x190 mm), with ball bearing slides
- Front centralized lock
- Vertically adjustable feet



C45PRO 2.0 ML

045002233 44 kg

Fixed module with built-in sink

- Stainless steel basin
- Supplied complete with:
 - 1 mixer tap
 - 1 drain unit
 - 1 sink stopper
 - 1 filter cap
 - 1 soap dispenser

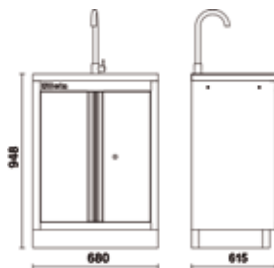

Fixed two-door module with lock:

- Usable interior dimensions: 600x603x416 mm
- With vertically adjustable feet

C45PRO 2.0 M3A

045000231 44 kg

Fixed module with 3 drawers and 2 doors

- 3 drawers (566x406 mm) with ball bearing slides
- Drawer bases protected by foamed rubber mats
- Can be fitted with thermoformed trays
- Front centralized lock
- Storage compartment with double door and lock (interior dimensions 670x440 mm), complete with intermediate shelf
- With vertically adjustable feet

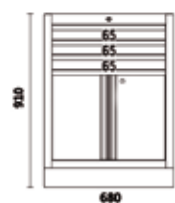

C45PRO 2.0 MAL

045000229 44,8 kg

Fixed module, 1360 mm long, with 2 sheet metal doors

- With lock
- Vertically adjustable interior shelf
- Interior dimensions: 1,355x420 mm
- With vertically adjustable feet

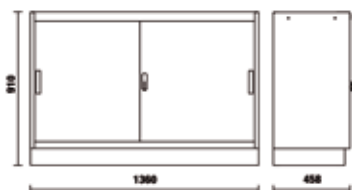

C45PRO 2.0 MAT

045000230 44,1 kg

Fixed module, 1360 mm long, with 2 clear polycarbonate doors

- With lock
- Vertically adjustable interior shelf
- Interior dimensions: 1,355x420 mm
- With vertically adjustable feet

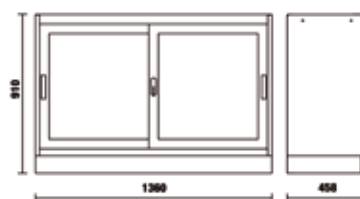

C45PRO 2.0 RD

Fixed sorted waste collection module

The ideal solution for sorted waste collection (glass, paper, plastics...)

- Sturdy sheet metal frame complete with 4 containers with up-and-over door for sorting waste
- Each container is fitted with: one removable plastic bin; capacity: 25 l
- 4 swivel castors, Ø 60 mm
- Supplied with kit of 4 coloured adhesive tapes
- With vertically adjustable feet



C45PRO 2.0 RD/X

045002241 80 kg

- Stainless steel coated MDF worktop (1360x615 mm)

C45PRO 2.0 RD/W

045002240 80 kg

- Multi-ply wood worktop (1,360x615 mm)



C45PRO 2.0 PM

045000302 10 kg

Wall-mounted cabinet

- Cabinet length: 680 mm
- With gas springs, making it easier to open and close door
- With lock

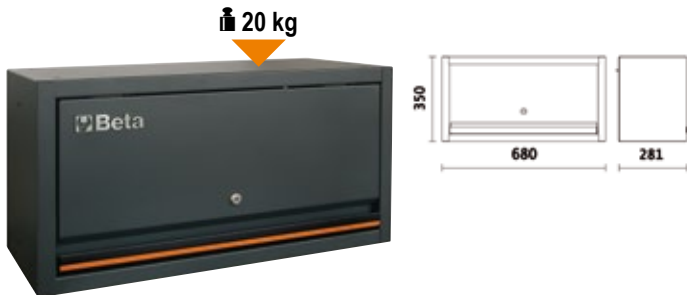

C45PRO 2.0 PML

045000303 17 kg

Wall-mounted cabinet, long version

- Cabinet length: 1360 mm
- With gas springs, making it easier to open and close door
- With lock



C45PRO 2.0 PAS

045000290 49,7 kg

Tool wall system

- Aluminium shutter, vertically adjustable, with lock
- Two removable perforated tool panels
- Can be used in combination with 1.3-m-long workbench
- 50-hook GPS kit included

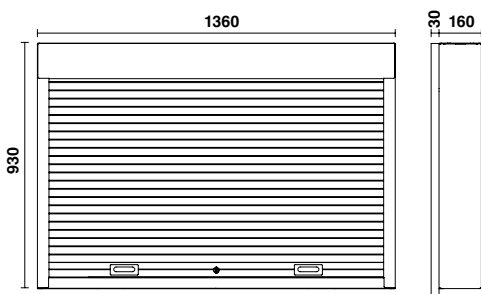

C45PRO 2.0 PF

045000313 5,3 kg

Perforated tool panel



1052x614,5x24 mm



C45PRO 2.0 PFE

045000312 5,3 kg

Perforated tool panel

- Can be fitted with 1 power socket (not included)



1052x614,5x24 mm

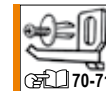

C45PRO 2.0 CPF

045000195 11 kg

Pair of perforated tool panels for mobile roller cab C45PRO MWS

- Supplied complete with framework
- 50-hook GPS kit included



1325x1678x30 mm

526,5 mm

C45PRO 2.0 SS

Side wall brackets

Narrow type

1420x32,5x30 mm

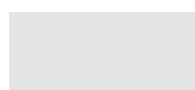

045000333 1,5 kg

C45PRO 2.0 SL

Side wall brackets

Wide type

1420x65x30 mm

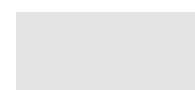

045000366 2 kg

C45PRO 2.0 MP

045000315 2,1 kg

Sheet metal shelf for perforated tool panels



614x160x80 mm

C45PRO 2.0 CORNER

Self-supporting complete corner

- Suspended corner cabinet with lock and 2 storage compartments
- 2 perforated tool panels (1,052x800 mm)
- Lower corner module with large storage compartment
- With vertically adjustable feet

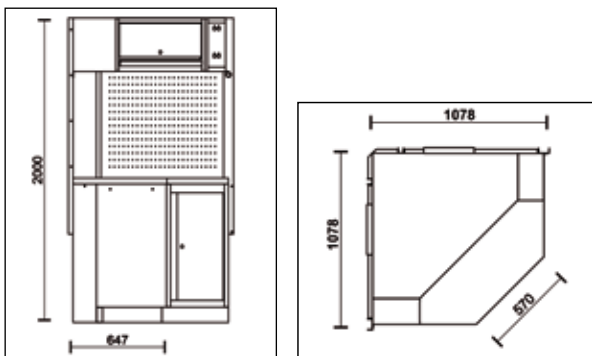

C45PRO 2.0 CORNER/X 045002401 127 kg

- Stainless steel coated MDF corner worktop (1,018x1,018 mm)

C45PRO 2.0 CORNER/W 045002411 119 kg

- Multi-ply wood corner worktop (1,018x1,018 mm)

C45PRO 2.0 CAI

Lower corner module

- Fixed corner module with large storage compartment
- With vertically adjustable feet

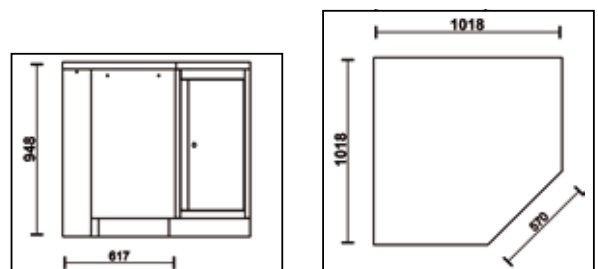

C45PRO 2.0 CAI/X 045002412 77 kg

- Stainless steel coated MDF corner worktop (1,018x1,018 mm)

C45PRO 2.0 CAI/W 045002402 69 kg

- Multi-ply wood corner worktop (1,018x1,018 mm)

C45PRO 2.0 AS1

045000451 57,5 kg

Sheet metal single-door tool cabinet with bracket

- 4 removable, vertically adjustable shelves
- Convenient folding clothes rail under first shelf
- With lock
- Sheet metal door can be installed with right or left opening
- Interior dimensions: 590x430 mm
- With vertically adjustable feet



C45PRO 2.0 A1/RB600

045000467 3,3 kg

Interior shelf for tool cabinet C45PRO 2.0 AS1, WITH CLOTHES RAIL

590x430 mm



CONVENIENT CLOTHES RAIL

C45PRO 2.0 A1/R600

045000466 2,5 kg

Interior shelf for tool cabinet C45PRO 2.0 AS1

590x430 mm

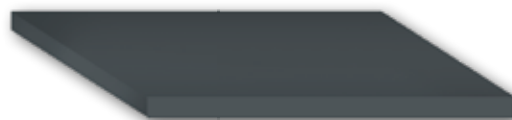

C45PRO 2.0 AS2

045000481 80 kg

Sheet metal two-door tool cabinet with bracket

- 4 removable, vertically adjustable shelves
- With lock
- Interior dimensions: 910x430 mm
- With vertically adjustable feet

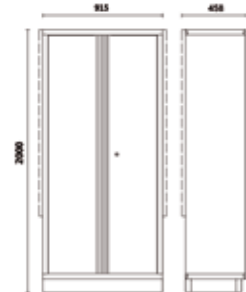

CAN BE ACCESSORISED WITH M3CA

70



C45PRO 2.0 AS2/3C

045000482 100,5 kg

Sheet metal two-door tool cabinet with 3 drawers and bracket

- 4 removable, vertically adjustable shelves
- **Supplied complete with 3-drawer (681x360 mm) module**
- Front lock
- Interior dimensions: 910x430 mm
- With vertically adjustable feet



C45PRO 2.0 A2/R915

045000496 4,5 kg

Interior shelf for tool cabinet

C45PRO 2.0 AS2

910x430 mm

50 kg



Choose one of the **C45PRO** combination with a **46 CM DEEP WORKTOP**

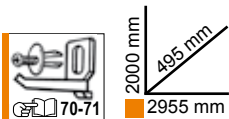

C45PRO X

045000001 305 kg

Combination comprising:

- **Stainless steel coated MDF worktop** (C45PX/3-2,0MT)
- **Fixed module with 5 drawers** (C45PRO M5)
- **Mobile roller cab with 7 drawers** (C45PRO C7)
- **Fixed service module** (C45PRO MS)
- **3 perforated tool panels** (C45PRO PF)
- **3 wall-mounted cabinets** (C45PRO PM)
- **3 wall brackets, wide type** (C45PRO SL)
- **1 wall bracket, narrow type** (C45PRO SS)
- **Two-door cabinet** (C45PRO AS2)

C45PRO AX

045000003 206 kg

Combination comprising:

- Stainless steel coated MDF worktop (C45PX/3-2,0MT)
- Fixed service module (C45PRO MS)
- Fixed module with 7 drawers (C45PRO M7)
- Fixed two-door module (C45PRO MA)
- 3 wall-mounted cabinets (C45PRO PM)
- 3 perforated tool panels (C45PRO PF)
- 2 wall brackets, wide type (C45PRO SL)
- 2 wall brackets, narrow type (C45PRO SS)

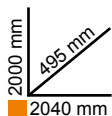

C45PRO 2.0 BX

045000021 191 kg

Combination comprising:

- Stainless steel coated MDF worktop (C45PX/2-1,3MT)
- Fixed module with 5 drawers (C45PRO M5)
- Fixed two-door module (C45PRO MA)
- 2 wall-mounted cabinets (C45PRO PM)
- 2 perforated tool panels (C45PRO PF)
- 2 wall brackets, wide type (C45PRO SL)
- 1 wall bracket, narrow type (C45PRO SS)
- Single-door cabinet (C45PRO AS1)

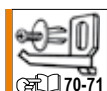
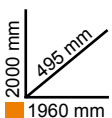

Do you already have a C45PRO workshop equipment and want to buy the new 2.0 version?

With our **EXTENSION KITS** nothing has ever been so simple.

MODERNITY AND PRACTICALITY IN JUST A FEW STEPS!

Worktop kit

- Thickness: 38 mm
- Can accommodate a vice (1599P/150, to be ordered separately)

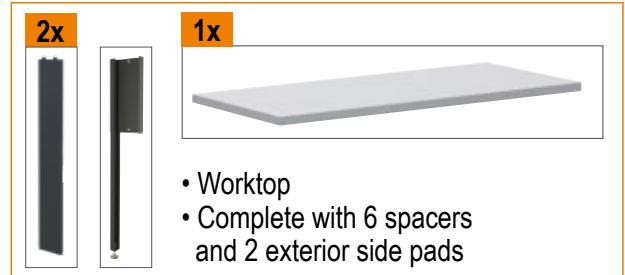

C45PRO 2.0 PXE Worktop made from stainless steel coated MDF



C45PRO 2.0 PXE/1-0,7MT	680x615x38 mm	2x	045002131	
C45PRO 2.0 PXE/2-1,3MT	1360x615x38 mm	4x	045002133	
C45PRO 2.0 PXE/3-2,0MT	2040x615x38 mm	6x	045002140	

C45PRO 2.0 PWE Worktop made from multi-ply wood



C45PRO 2.0 PWE/1-0,7MT	680x615x38 mm	2x	045002141	
C45PRO 2.0 PWE/2-1,3MT	1360x615x38 mm	4x	045002143	
C45PRO 2.0 PWE/3-2,0MT	2040x615x38 mm	6x	045002150	

Modular extension low corner kit

- Corner worktop (1018x1018 mm)
- 4 partitions
- 2 lateral fillings

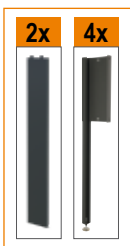

Modular extension complete corner kit

- Corner worktop (1018x1018 mm)
- 4 partitions
- 2 lateral fillings
- 2 object holders
- 1 upright

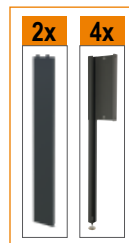

C45PRO 2.0 CAI/KEPX

045002500

- Stainless steel coated MDF corner worktop

C45PRO 2.0 CORNER/KEPX

045002510

- Stainless steel coated MDF corner worktop

C45PRO 2.0 CAI/KEPW

045002505

- Multi-ply wood corner worktop

C45PRO 2.0 CORNER/KEPW

045002515

- Multi-ply wood corner worktop

5945VUM

Assortment of 199 tools in EVA foam trays

059451011 19,6 kg

MM11

30



- 42 ☎ 6-7-8-9-10-11-12-13-14-15-16-17-18-19-20-21-22-24-27-30-32 mm
- 96BPC/SC9 ○ 1,5-2-2,5-3-4-5-6-8-10 mm

MM105MH

107

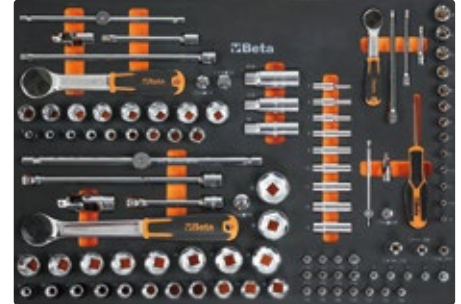

1/4" 3/8" 1/2"

- 895/1 ○ 1/4-□ 1/4
- 895/3 ○ 1/4-□ 3/8
- 895/6 ○ 5/16-□ 1/2
- 900 ○ 4-4,5-5-5,5-6-7-8-9-10-11-12-13-14 mm
- 900L ○ 5-6-7-8-9-10-11-12-13 mm
- 900ME ○ 3-4-5-6-7 mm
- 900LP ● 0,8x4-1x5,5-1,2x6,5-1,2x8
- 900PH ⊕ PH1-PH2-PH3-PH4
- 900TX ⊙ T10-T15-T20-T25-T27-T30-T40
- 900/16
- 900/... 50-100-150 mm
- 900/25
- 900BG/31 176 mm
- 900/42 115 mm
- 900/55 ⊕ 125 mm
- 910A ○ 6-7-8-9-10-11-12-13-14-15-16-17-18-19-20-21-22 mm
- 910/15 □ 3/8-■ 1/4
- 910/16 □ 3/8-■ 1/2
- 910/21 125 mm
- 910/22 250 mm
- 910/25
- 910/42 210 mm
- 910/55 ⊕ 200 mm
- 920A ○ 8-10-11-12-13-14-15-16-17-18-19-20-21-22-23-24-26-27-28-30-32 mm
- 920/15 □ 1/2-■ 3/8
- 920/25
- 920AN 125-250 mm
- 920/42 305 mm
- 920/55 ⊕ 275 mm
- 956E ○ 16 mm (5/8")-17,8 (11/16")-20,8 (13/16")

MM129

12



- 1032 ○ 180 mm
- 1034 ○ 170 mm
- 1036 ● 175 mm
- 1038 ● 175 mm
- 1048N 250 mm
- 1052 240 mm
- 1082BM ↗ 160 mm
- 1098 220 mm
- 1128BMX
- 1150BM = 180 mm
- 1166BM ● 160 mm
- 1168BM ● 160 mm

MM210

25



- 1201E ● 2,5x50-3x75-4x100-5,5x125-6,5x150-8x200 mm
- 1201EN ● 4x30 mm
- 1202E ⊕ PH0x60-PH1x80-PH2x100-PH3x150 mm
- 1201EN ⊕ PH1X30 mm
- 1207E/TX ⊙ T6-T7-T8-T9-T10-T15-T20-T25-T27-T30-T40-T45
- 1253 ● 3,5x100 mm

MM230

25



- 30 Ø 2-3-4 mm
- 31 Ø 2-3-4-5-6-8 mm
- 32 Ø 4 mm
- 34 150 mm
- 35 200-250 mm
- 36 125 mm
- 1370 500 g
- 1390 Ø 35 mm
- 1692 3 m
- 1712TF
- 1719BMA...Q 200 mm
- 1719BMA...T 200 mm
- 1719BMA...P 200 mm
- 1719BMA...M 200 mm
- 1719BMA...R 200 mm
- 1737NX
- 1771

66-67

Accessories 68

SSPE

088880482 6 kg

Under-cabinet support for power tools

- For use only under suspended cabinet C45PRO 2.0 PM (workshop equipment C45PRO 2.0)
- With 5 convenient slots for accommodating power tools



680x280x150 mm

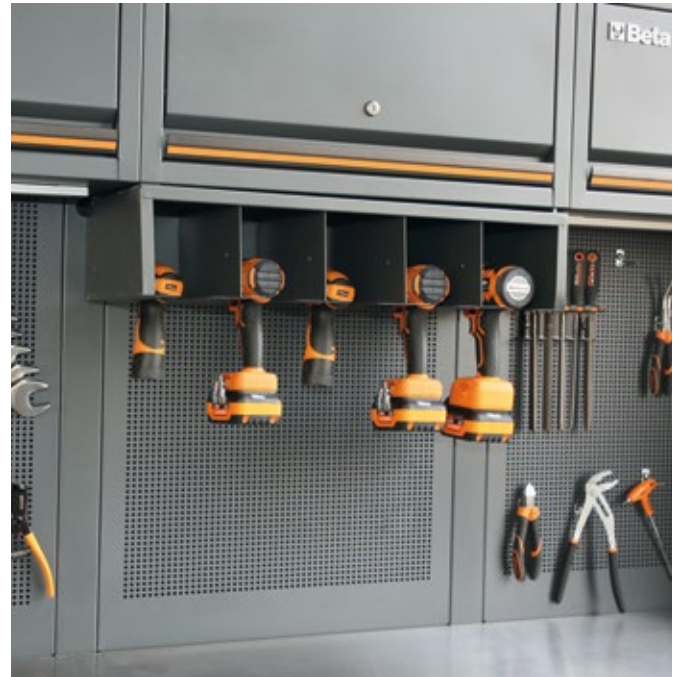

8889 PS/7

088890407 1,3 kg

Parallel partitions for item C45PRO 2.0 M4/M5/M7/M8/M3A/ACT/TC

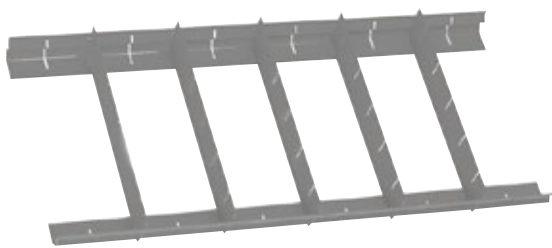

8889 CS/7

088890417 1,9 kg

Crossed partitions for item C45PRO 2.0 M4/M5/M7/M8/M3A/ACT/TC

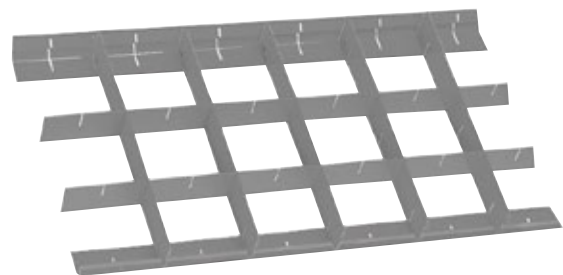

C45STR

Coloured adhesive tape

- Allows tailoring of colour of horizontal and vertical inserts in workshop equipment combination C45PRO 2.0

RAL2011
RAL9006
RAL3000
RAL5015
RAL1023
RAL6029

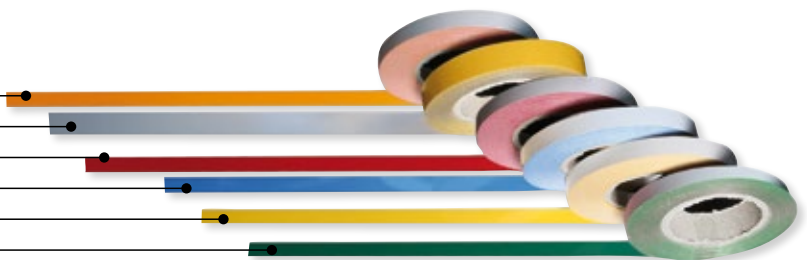

C45STR-0/2011	30 m	045000911		
C45STR-G/9006	25 m	045000912		
C45STR-R/3000	25 m	045000913		

C45STR-B/5015	25 m	045000914		
C45STR-Y/1023	25 m	045000915		
C45STR-V/6029	25 m	045000916		

Introduction	36-37
Comprehensive combinations	38÷49
Worktops	51
Mobile roller cabs	52
Fixed modules	53÷56
Perforated panels and wall units	57-58
Corners	59-60
Cabinets	61-62
Accessories	63; 68÷71
Reels	64-65
Assortments	66-67
3D configurator	72
Customised modules	73

**Workshop equipment RSC50 2.0,
designed and manufactured at Beta's
Italian-based factories, caters for the needs
of professionals wishing to match
DESIGN, FUNCTIONALITY AND DURABILITY**



COMBINATIONS

Workshop equipment RSC50 2.0 is the name for preassembled combinations developed by Beta for professionals; alternatively, it allows you to design your workplace on your own, choosing from many under-bench modules, wall-mounted cabinets and furnishing accessories.

It can be further customised with accessories, coloured drawer fronts and lights.

The sturdy **70-cm-deep worktop**, provides a convenient work surface. It can be fitted with a vice, thereby allowing heavy-duty jobs to be carried out.

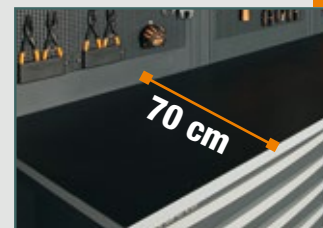

It is available in **sheet metal, multi-ply wood or stainless steel coated MDF.**

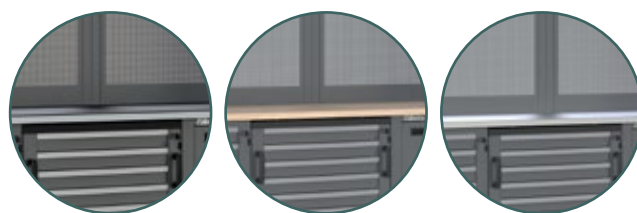

Workshop equipment RSC50 is fitted with standard-sized drawers (588x367 mm), which are compatible with Beta's wide range of tool modules, available in both soft EVA and hard ABS versions.



ASSEMBLY

Watch the assembly videos



QUICK, USER-FRIENDLY ASSEMBLY is also a major hallmark, based on manufacturing optimisation of the modules of the range.

REQUEST THE ASSEMBLY service with highly trained personnel, to assemble your workshop equipment combination in your garage or workshop, professionally and quickly.



The service is available for the following combinations:

RSC50 2.0 I	050001046	RSC50 2.0	050001001	RSC50 2.0 G	050001036	RSC50 2.0 FX	050001032
RSC50 2.0 L	050001051	RSC50 2.0 H	050001041	RSC50 2.0 F	050001031	RSC50 2.0 FW	050001033

Ask your dealer for a customised quotation and book the service.



RSC50 2.0
A1

RSC50 2.0
P/2MDX-SX

RSC50 2.0
NPG/3-2,2MT

RSC50 2.0
PM

RSC50 2.0
M7

RSC50 2.0
C7

RSC50 2.0
MS-2C

Combination comprising the following:

- 1 worktop, 2,240x700 mm (RSC50 2.0 NPG/3-2.2MT)
- 1 worktop, 1,495x700 mm (RSC50 2.0 NPG/2-1,5MT)
- 1 fixed module with 7 drawers (RSC50 2.0 M7)
- 1 mobile roller cab with 7 drawers (RSC50 2.0 C7)
- 1 fixed service module with 2 drawers (RSC50 2.0 MS-2C)
- 1 self-supporting complete corner (RSC50 2.0 NAC-G)
- 1 fixed module with 5 drawers (RSC50 2.0 M5)
- 1 fixed two-door module (RSC50 2.0 MA)
- 5 wall-mounted cabinets (RSC50 2.0 PM)
- 5 upper perforated tool panels (RSC50 2.0 PFS)
- 5 lower perforated tool panels (RSC50 2.0 PFI)
- 5 pairs of right/left uprights (RSC50 2.0 P/2MDX-SX)
- 2 single-door cabinets (RSC50 2.0 A1)

RSC50 2.0
NAC-G

RSC50 2.0
NPG/2-1,5MT

RSC50 2.0
PFI-PFS



RSC50 2.0
M5

RSC50 2.0
MA

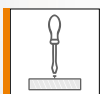
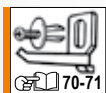

Combination comprising the following:

- 1 worktop, 2,240x700 mm (RSC50 2.0 NPG/3-2.2MT)
- 1 worktop, 750x700 mm (RSC50 2.0 NPG/1-0.7MT)
- 1 fixed service module (RSC50 2.0 MS-2AVV) with compressed air hose reel item 1900S 8x10 and cable reel item 1844 15-H05/SCK (included)
- 1 mobile roller cab with 7 drawers (RSC50 2.0 C7)
- 1 fixed module with 7 drawers (RSC50 2.0 M7)
- 1 self-supporting complete corner (RSC50 2.0 NAC-G)
- 1 fixed two-door module (RSC50 2.0 MA)
- 1 tool wall system with aluminium shutter and framework (RSC50 2.0 PS)
- 2 wall-mounted cabinets (RSC50 2.0 PM)
- 2 upper perforated tool panels (RSC50 2.0 PFS)
- 2 lower perforated tool panels (RSC50 2.0 PFI)
- 2 pairs of right/left uprights (RSC50 2.0 P/2MDX-SX)
- 2 single-door cabinets (RSC50 2.0 A1)

INCLUDED



1900S 8x10



1844 15-H05/SCK

050001051 720 kg



RSC50 2.0

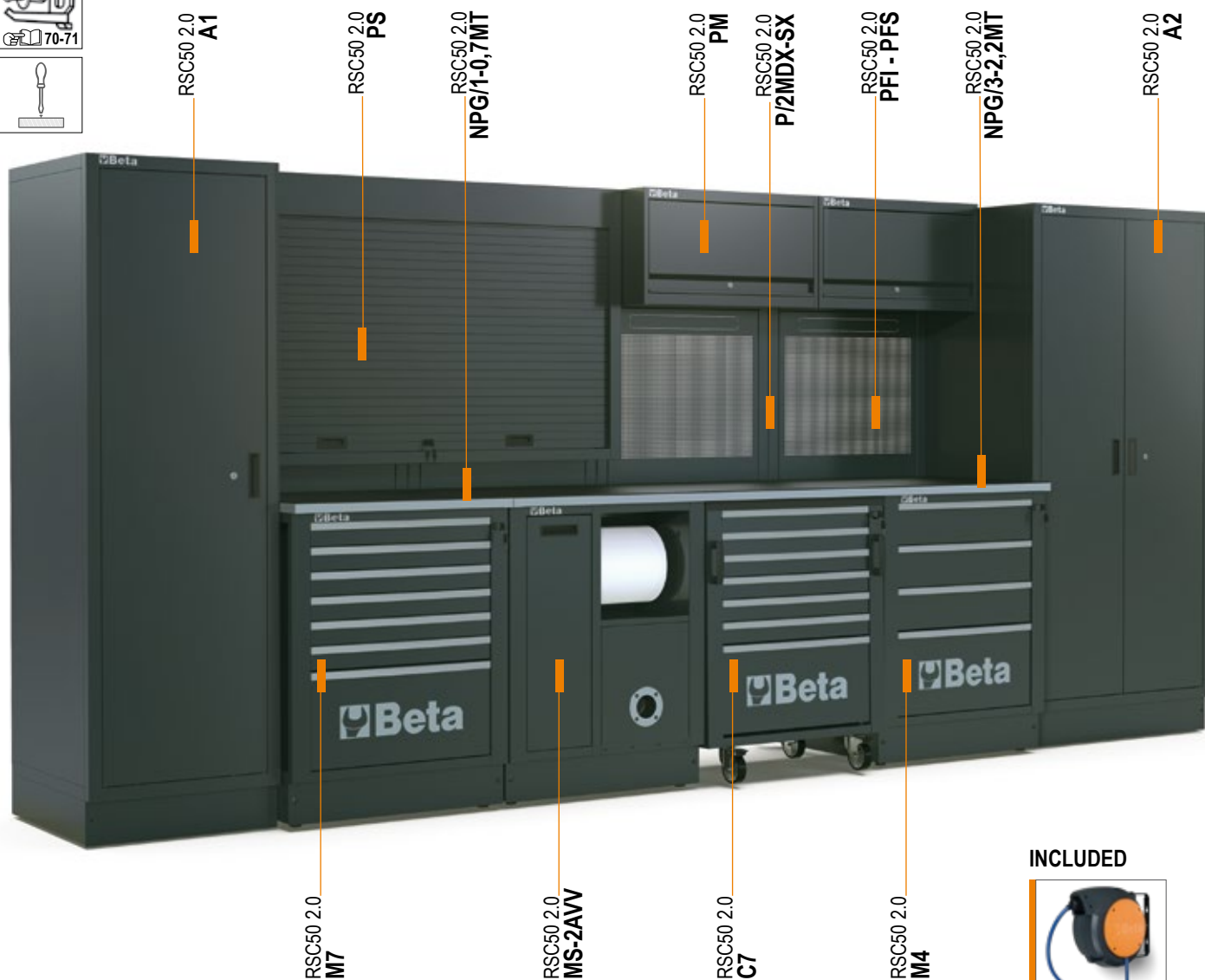

RSC50 2.0
A1

RSC50 2.0
PS

RSC50 2.0
NPG/1-0,7MT

RSC50 2.0
PM

RSC50 2.0
P/2MDX-SX

RSC50 2.0
PFI - PFS

RSC50 2.0
NPG/3-2,2MT

RSC50 2.0
A2

RSC50 2.0
M7

RSC50 2.0
MS-2AV

RSC50 2.0
C7

RSC50 2.0
M4

INCLUDED



1900S 8x10

Combination comprising the following:

- 1 single-door cabinet (RSC50 2.0 A1)
- 1 worktop, 750x700 mm (RSC50 2.0 NPG/1-0.7MT)
- 1 worktop, 2,240x700 mm (RSC50 2.0 NPG/3-2.2MT)
- 1 mobile roller cab with 7 drawers (RSC50 2.0 C7)
- 1 fixed module with 4 drawers (RSC50 2.0 M4)
- 1 fixed module with 7 drawers (RSC50 2.0 M7)
- 1 fixed service module (RSC50 2.0 MS-AV)
with compressed air hose reel item 1900S 8x10 (included)
- 1 tool wall system with aluminium shutter and framework (RSC50 2.0 PS)
- 2 wall-mounted cabinets (RSC50 2.0 PM)
- 2 upper perforated tool panels (RSC50 2.0 PFS)
- 2 lower perforated tool panels (RSC50 2.0 PFI)
- 2 pairs of right/left uprights (RSC50 2.0 P/2MDX-SX)
- 1 two-door cabinet (RSC50 2.0 A2)



050001001 604 kg

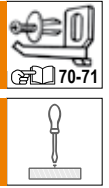

Combination comprising the following:

- 1 worktop, 2.240x700 mm (RSC50 2.0 NPG/3-2,2MT)
- 1 fixed service module with 2 drawers (RSC50 2.0 MS-2C)
- 1 mobile roller cab with 7 drawers (RSC50 2.0 C7)
- 1 fixed module with 7 drawers (RSC50 2.0 M7)
- 1 fixed module with built-in sink (RSC50 2.0 ML)
- 4 wall-mounted cabinets (RSC50 2.0 PM)
- 4 upper perforated tool panels (RSC50 2.0 PFS)
- 4 lower perforated tool panels (RSC50 2.0 PFI)
- 4 pairs of right/left uprights (RSC50 2.0 P/2MDX-SX)
- 1 single-door cabinet (RSC50 2.0 A1)

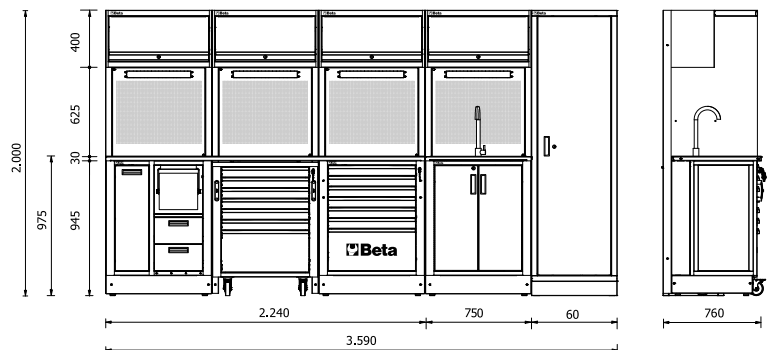

050001041 464 kg

RSC50 2.0 G



Combination comprising the following:

- 1 worktop, 2,240x700 mm (RSC50 2.0 NPG/3-2.2MT)
- 1 fixed service module (RSC50 2.0 MS-2AVV) with compressed air hose reel item 1900S 8x10 and cable reel item 1844 15-H05/SCK (included)
- 1 mobile roller cab with 7 drawers (RSC50 2.0 C7)
- 1 fixed module with 4 drawers (RSC50 2.0 M4)
- 3 wall-mounted cabinets (RSC50 2.0 PM)
- 3 upper perforated tool panels (RSC50 2.0 PFS)
- 3 lower perforated tool panels (RSC50 2.0 PFI)
- 3 pairs of right/left uprights (RSC50 2.0 P/2MDX-SX)
- 1 two-door cabinet (RSC50 2.0 A2)

INCLUDED



1900S 8x10



1844 15-H05/SCK



050001036 416 kg

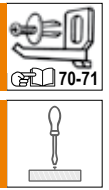

RSC50 2.0 F

050001031 411 kg

Combination comprising the following:

- 1 worktop, 2,240x700 mm (RSC50 2.0 NPG/3-2.2MT)
- 1 fixed module with 7 drawers (RSC50 2.0 M7)
- 1 mobile roller cab with 7 drawers (RSC50 2.0 C7)
- 1 fixed service module with 2 drawers (RSC50 2.0 MS-2C)
- 3 wall-mounted cabinets (RSC50 2.0 PM)
- 3 upper perforated tool panels (RSC50 2.0 PFS)
- 3 lower perforated tool panels (RSC50 2.0 PFI)
- 3 pairs of right/left uprights (RSC50 2.0 P/2MDX-SX)
- 1 two-door cabinet (RSC50 2.0 A2)

RSC50 2.0 FX

050001032 405 kg

- 1 worktop (2,240x700 mm) made from **stainless steel coated MDF** (RSC50 2.0 PX/3-2.2MT)

RSC50 2.0 FW

050001033 386kg

- 1 worktop (2,240x700 mm) made from **multi-ply wood** (RSC50 2.0 PW/3-2.2MT)



RSC50 2.0 E

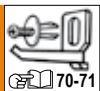

Combination comprising the following:

- 1 worktop, 2,240x700 mm (RSC50 2.0 NPG/3-2.2MT)
- 1 fixed service module with 2 drawers (RSC50 2.0 MS-2C)
- 1 fixed module with 7 drawers (RSC50 2.0 M7)
- 1 fixed two-door module (RSC50 2.0 MA)
- 3 wall-mounted cabinets (RSC50 2.0 PM)
- 3 upper perforated tool panels (RSC50 2.0 PFS)
- 3 lower perforated tool panels (RSC50 2.0 PFI)
- 3 pairs of right/left uprights (RSC50 2.0 P/2MDX-SX)

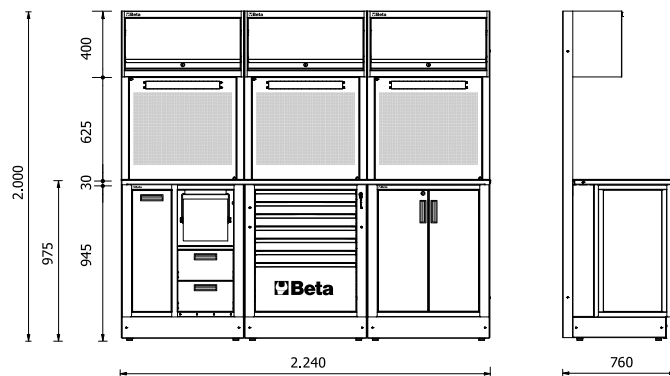

050001026 310 kg



RSC50 2.0 D

050001021 276 kg

Combination comprising the following:

- 1 worktop, 1,495x700 mm (RSC50 2.0 NPG/2-1.5MT)
- 1 fixed module with 7 drawers (RSC50 2.0 M7)
- 1 fixed two-door module (RSC50 2.0 MA)
- 2 wall-mounted cabinets (RSC50 2.0 PM)
- 2 upper perforated tool panels (RSC50 2.0 PFS)
- 2 lower perforated tool panels (RSC50 2.0 PFI)
- 2 pairs of right/left uprights (RSC50 2.0 P/2MDX-SX)
- 1 single-door cabinet (RSC50 2.0 A1)

RSC50 2.0 DX

050001023 275 kg

- 1 worktop (1,495x700 mm) made from **stainless steel coated MDF** (RSC50 2.0 PX/2-1.5MT)

RSC50 2.0 DW

050001024 263 kg

- 1 worktop (1,495x700 mm) made from **multi-ply wood** (RSC50 2.0 PW/2-1.5MT)



RSC50 2.0 C



Combination comprising the following:

- 1 worktop, 1,495x700 mm (RSC50 2.0 NPG/2-1.5MT)
- 1 fixed service module with 2 drawers (RSC50 2.0 MS-2C)
- 1 fixed module with 7 drawers (RSC50 2.0 M7)
- 2 wall-mounted cabinets (RSC50 2.0 PM)
- 2 upper perforated tool panels (RSC50 2.0 PFS)
- 2 lower perforated tool panels (RSC50 2.0 PFI)
- 2 pairs of right/left uprights (RSC50 2.0 P/2MDX-SX)
- 1 single-door cabinet (RSC50 2.0 A1)



050001016 279 kg

RSC50 2.0 B

Combination comprising the following:

- 1 worktop, 1,495x700 mm (RSC50 2.0 NPG/2-1.5MT)
- 1 fixed two-door module (RSC50 2.0 MA)
- 1 fixed module with 7 drawers (RSC50 2.0 M7)
- 1 tool wall system with aluminium shutter and framework (RSC50 2.0 PS)

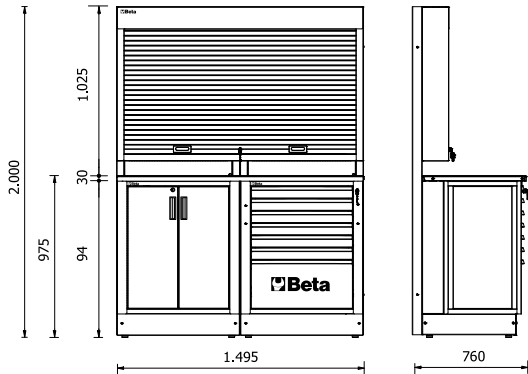

050001011 224 kg

RSC50 2.0 A

Combination comprising the following:

- 1 worktop, 1,495x700 mm (RSC50 2.0 NPG/2-1.5MT)
- 1 fixed module with 7 drawers (RSC50 2.0 M7)
- 1 fixed service module with 2 drawers (RSC50 2.0 MS-2C)
- 2 wall-mounted cabinets (RSC50 2.0 PM)
- 2 upper perforated tool panels (RSC50 2.0 PFS)
- 2 lower perforated tool panels (RSC50 2.0 PFI)
- 2 pairs of right/left uprights (RSC50 2.0 P/2MDX-SX)

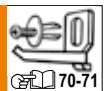
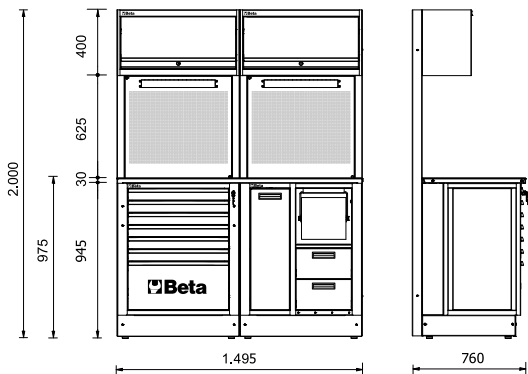

050001006 212 kg

CREATE YOUR CUSTOMISED WORKSHOP FROM SCRATCH

Workspace RSC50 2.0 can be configured from scratch and catered to satisfy one's requirements, based on a large choice of:

WORKTOP

in painted sheet metal, stainless steel coated MDF or multi-ply wood

 51

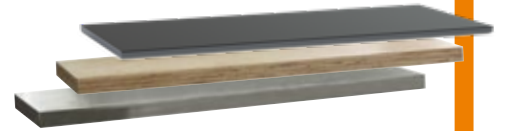

MOBILE ROLLER

 52



FIXED MODULE

 53÷56



PERFORATED PANELS AND WALL UNITS

 57-58

CORNERS

 59-60

CABINETS

 61-62



ASSORTMENTS

 66-67

ACCESSORIES

 63; 64-65; 68÷71

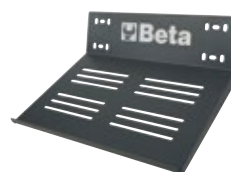

 3D configurator  72

RSC50 2.0 NP

- Holes for a vice (1599P/125, to be ordered separately) on both sides

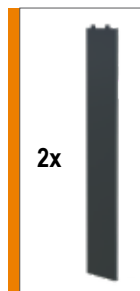

Supplied complete with two exterior side pads.

Painted sheet metal worktop, covered with a shockproof, non-scratch PVC coat, resistant to hydrocarbons.

Designed for application of aluminium profiles with LED strips item 5000 RSC50/PLED or 5000 RSC50/PLED-ST (to be ordered separately), to light under-workbench modules.



RAL 7046	L mm	P mm	kg		
RSC50 2.0 NPG/1-0,7MT	750	700	16,7	050001118	
RSC50 2.0 NPG/2-1,5MT	1.495	700	31	050001125	€ 0
RSC50 2.0 NPG/3-2,2MT	2.240	700	49,6	050001133	

RAL 7016	L mm	P mm	kg		
RSC50 2.0 NPA/1-0,7MT	750	700	16,7	050001117	
RSC50 2.0 NPA/2-1,5MT	1.495	700	31	050001124	0
RSC50 2.0 NPA/3-2,2MT	2.240	700	49,6	050001132	

Worktop made from **multi-ply wood**



WOOD	L mm	P mm	kg		
RSC50 2.0 PW/1-0,7MT	750	700	7	050001126	
RSC50 2.0 PW/2-1,5MT	1.495	700	14,5	050001130	
RSC50 2.0 PW/3-2,2MT	2.240	700	21	050001136	

Worktop made from **stainless steel coated MDF**



INOX	L mm	P mm	kg		
RSC50 2.0 PX/1-0,7MT	750	700	13,5	050001127	
RSC50 2.0 PX/2-1,5MT	1.495	700	27	050001131	
RSC50 2.0 PX/3-2,2MT	2.240	700	40,5	050001137	

Shock-proof, non-scratch PVC coat, resistant to hydrocarbons

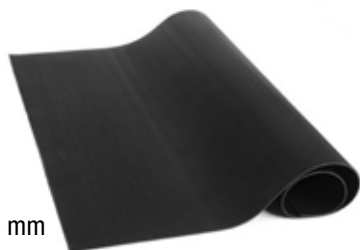

Thickness 2,5 mm

COATING PVC	L mm	P mm	kg		NEW
RSC50 2.0 RB/0,75	750	700	2,0	050001160	
RSC50 2.0 RB/0,96	964	700	3,0	050001161	
RSC50 2.0 RB/1,5	1.495	700	3,8	050001162	
RSC50 2.0 RB/2,2	2.240	700	5,5	050001163	

1599P/125

Parallel bench vices

- Hardened jaws
- Anvil with large lacquered surface
- Square steel base

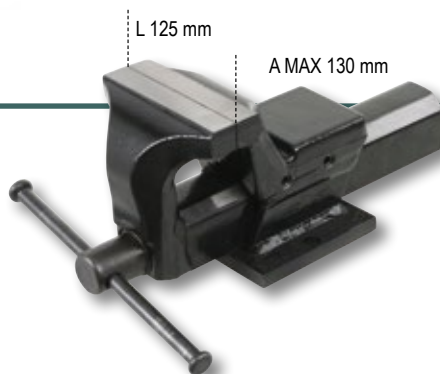

015990025 9,5 kg

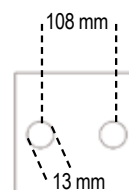

Mobile roller cabs

Features:

- Drawers (588x367 mm) with ball bearing slides
- 4 swivel castors, Ø 100 mm (2 with brakes)
- Drawer bases protected by foamed rubber mats
- Front centralized lock
- Handles built into frame for improved ease of handling
- Each drawer can accommodate **up to 4 EVA foam or ABS thermoformed trays**

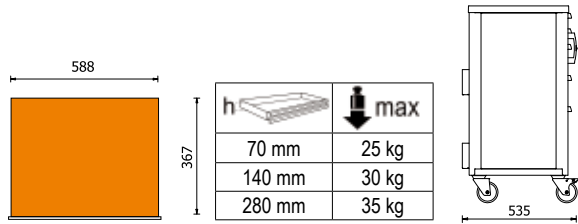

RSC50 2.0 C5

050001205

58 kg

Mobile roller cab with 5 drawers



RSC50 2.0 C6

050001206

61 kg

Mobile roller cab with 6 drawers



RSC50 2.0 C7

050001207

62 kg

Mobile roller cab with 7 drawers



RSC50 2.0 C8

050001208

64 kg

Mobile roller cab with 8 drawers



RSC50 2.0 T3

050001253

23 kg

3-tier tool trolley

- Static load capacity: 200 kg (distributed over 3 shelves)



Fixed module

Features:

- 4 drawers (588x367 mm) with ball bearing slides
- Drawer bases protected by foamed rubber mats
- Front centralized lock
- With vertically adjustable feet
- Each drawer can accommodate **up to 4 EVA foam or ABS thermoformed trays**

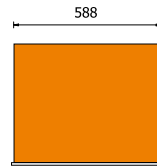

h	max
70 mm	25 kg
140 mm	30 kg
280 mm	35 kg

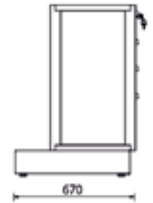

RSC50 2.0 M4

050001264 61,5 kg

Fixed module with 4 drawers

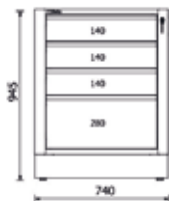

RSC50 2.0 M5

050001265 63,5 kg

Fixed module with 5 drawers



RSC50 2.0 M6

050001226 65,5 kg

Fixed module with 6 drawers

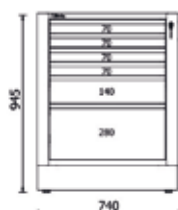

RSC50 2.0 M7

050001267 67,5 kg

Fixed module with 7 drawers

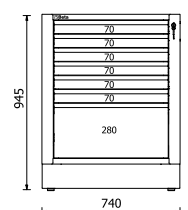

Fixed module



RSC50 2.0 M8

050001268 69,5 kg

Fixed module with 8 drawers

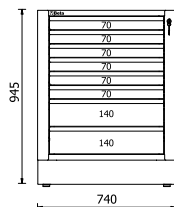

RSC50 2.0 M10

050001231 76 kg

Fixed module with 10 drawers

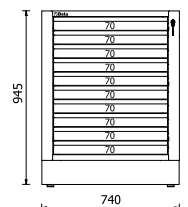

RSC50 2.0 MS-2C

050001283 49 kg

Fixed service module

- Two drawers, 310x370 mm, 180 mm high, with ball bearing slides (interior dimensions)
- With vertically adjustable feet

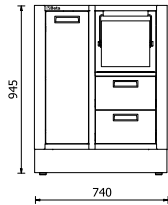

Paper roll compartment



Built-in waste bin

RSC50 2.0 MS-AVV

050001281 49 kg

Fixed service module

Can accommodate **one reel**, to be chosen from the following models:

RSC50 2.0 MS-2AVV

050001282 50 kg

Fixed service module

Can accommodate **two reels**, to be chosen from the following:

- Compressed air hose reel item 1900S 8x10
- Cable reels items 1843 15-H05, 1844 10-H05, 1844 15-H05, 1844 15-H07, 1844 15-H05/SCK, 1844 15-H07/SCK, 1845 12-H05, 1846 10-H05, 1846 10-H07 and 1846 15-H05 (to be ordered separately)

- Built-in waste bin
- Paper roll compartment
- With vertically adjustable feet

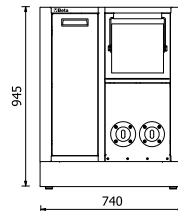
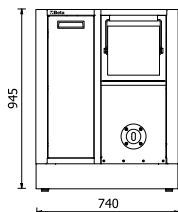

RSC50 2.0 MA

050001262 46 kg

Fixed two-door module

- With lock
- Vertically adjustable interior shelf
- Interior dimensions: 615x435x740 mm
- With vertically adjustable feet



RSC50 2.0 CS

050001285 48 kg

Fixed sorted waste collection module

- Pull-out waste compartment (588x355x580 mm) with ball bearing slides
- 2 capacious pull-out interior containers for sorting waste
- With vertically adjustable feet



RSC50 2.0 ML

050001284 39 kg

Fixed module with built-in sink

- Stainless steel basin
- Supplied complete with:
 - 1 mixer tap
 - 1 drain unit
 - 1 sink stopper
 - 1 filter cap
 - 1 soap dispenser

Fixed two-door module with lock:

- Usable interior dimensions: 615x435x575 mm
- With vertically adjustable feet

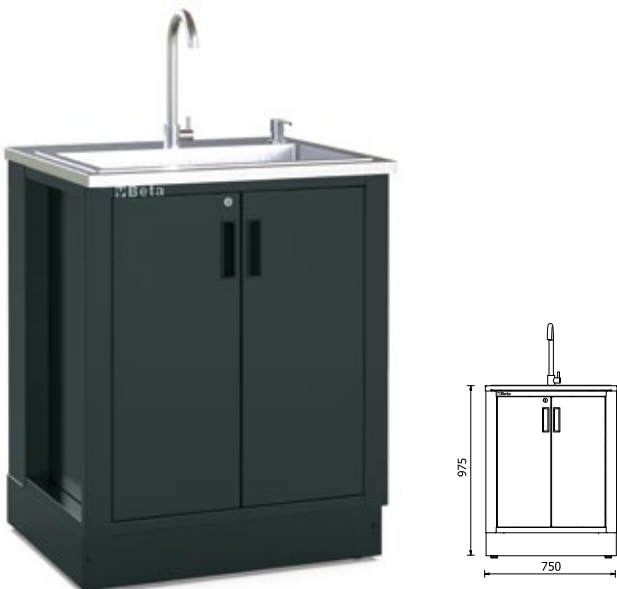

RSC50 2.0 MDO

050001290 92 kg

Fixed oil distribution

- 2 hose reels 7 m - 1/2" included
- Complete with 2 guns with digital litre counter and automatic drip catcher.
 - Max. flow rate: 30 l/min
 - Viscosity: 8÷2000 mPas
- With vertically adjustable feet

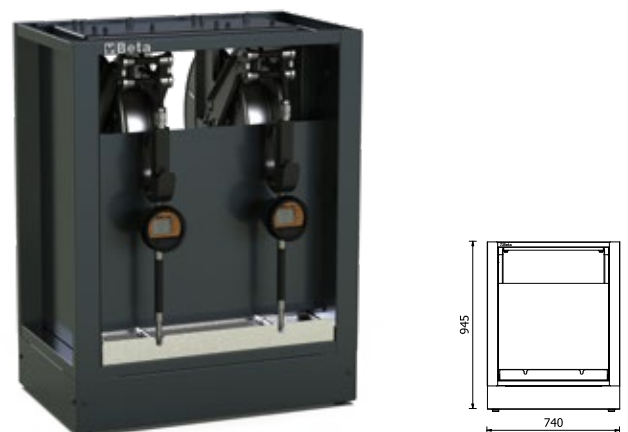

RSC50 2.0 PM

050001302 14 kg

Wall-mounted cabinet

- Fitted with gas springs, making it easier to open and close door
- Designed for application of aluminium profiles with LED strip item 5000 RSC50 2.0/PLEDC or 5000 RSC50 2.0/PLED-ST (to be ordered separately), to light working area beneath and/or interior of suspended cabinet

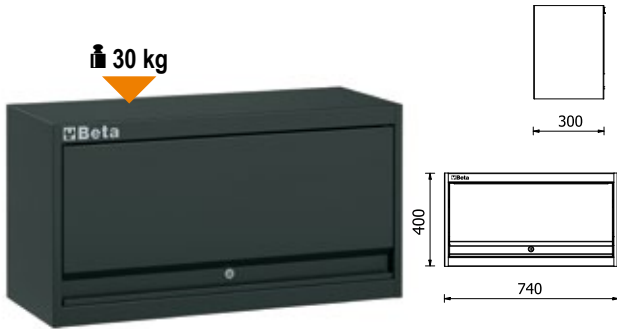

5000 RSC50 2.0/CLL

050001710 1 kg

Linear guard

- To be applied to perforated tool panels
- Designed for application of aluminium profiles with LED strip item 5000 RSC50 2.0/PLEDC or 5000 RSC50 2.0/PLED-ST (to be ordered separately), to light working area beneath



RSC50 2.0 MTP

050001305 5 kg

Triangular shelf

- Designed for application of aluminium profiles with LED strip item 5000 RSC50 2.0/PLEDC or 5000 RSC50 2.0/PLED-ST (to be ordered separately), to light working area beneath



5000 RSC50 2.0/MP

050001705 2 kg

Shelf

- Designed for application of aluminium profiles with LED strip item 5000 RSC50 2.0/PLEDC or 5000 RSC50 2.0/PLED-ST (to be ordered separately), to light working area beneath



RSC50 2.0 PS

050001360 80 kg

Tool wall system with shutter

- Aluminium shutter, vertically adjustable, with lock
- Removable perforated tool panels
- Supplied with framework
- 50-hook GPS kit included

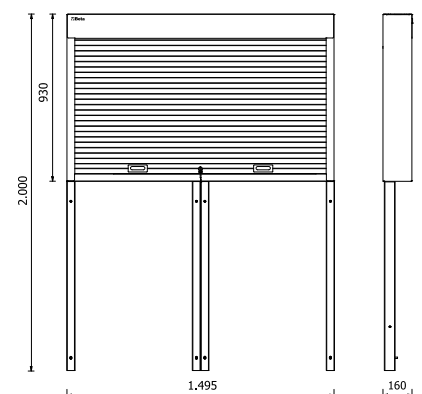
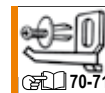

RSC50 2.0 PFS

050001312 3 kg

Upper perforated tool panel

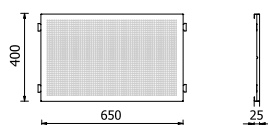
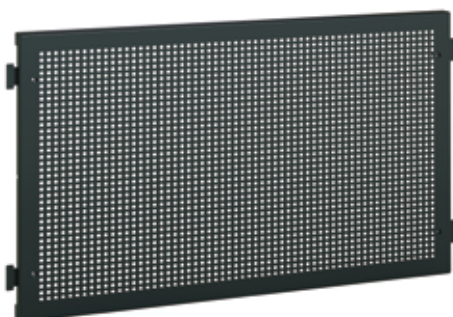

RSC50 2.0 PFI

050001313 4,5 kg

Lower perforated tool panel

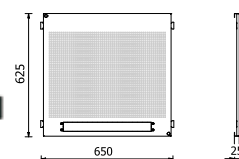
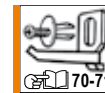

RSC50 2.0 KPF

050001310 17,5 kg

Kit of perforated tool panels

- One upper perforated tool panel, 650x400x25 mm
- One lower perforated tool panel, 650x625x25 mm, can accommodate a 19" rack multi-socket (not included)
- One pair of right/lefts uprights

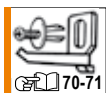

Can accommodate a 19" rack multi-socket (not included)



RSC50 2.0 P/2MDX-SX

050001352 8,5 kg

Pair of right/left uprights for perforated tool wall systems

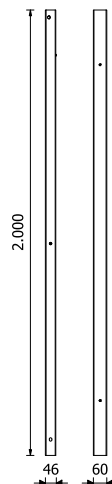
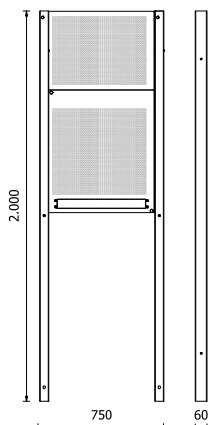

Lower corner module

with large storage compartment

- With vertically adjustable feet

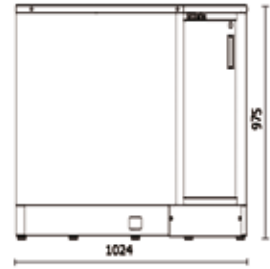

RSC50 2.0 KNAI

- Worktop (964x964 mm) made from **painted sheet metal** covered with a shockproof, non-scratch PVC coat, resistant to hydrocarbons



RAL 7046

RSC50 2.0 KNAI-G 050001346 80 kg



RAL 7016

RSC50 2.0 KNAI-A 050001345 80 kg



RSC50 2.0 KNAI-X 050001338 85 kg

- Corner worktop (964x964 mm) made from **stainless steel coated MDF**

RSC50 2.0 KNAI-W 050001337 76 kg

- Corner worktop (964x964 mm) made from **multi-ply wood**



Self-supporting complete corner

- Suspended corner cabinet with lock and gas springs, making it easier to open and close door
- 2 perforated tool panels (869x1,027 mm)
- Lower corner module with large storage compartment
- With vertically adjustable feet

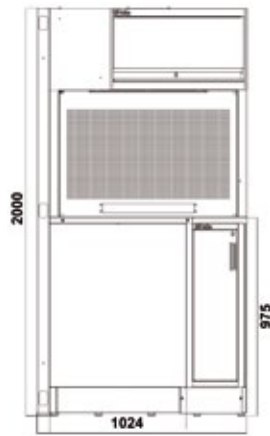

RSC50 2.0 NAC

- Corner worktop (964x964) made from painted sheet metal covered with a shockproof, non-scratch PVC coat, resistant to hydrocarbons

RAL 7046

RSC50 2.0 NAC-G

050001340 143 kg



RAL 7016

RSC50 2.0 NAC-A

050001339 143 kg



RSC50 2.0 NAC-X

050001328 148 kg

- Corner worktop (964x964 mm) made from **stainless steel coated MDF**



RSC50 2.0 NAC-W

050001327 139 kg

- Corner worktop (964x964 mm) made from **multi-ply wood**



RSC50 2.0 A1

050001411 67 kg

Sheet metal single-door tool cabinet

- 4 removable, vertically adjustable shelves
- With lock
- Sheet metal door can be installed with right or left opening
- Interior dimensions: 596x605 mm
- With vertically adjustable feet

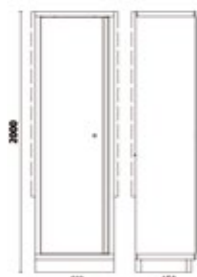

RSC50 2.0 A1/RB59

050001914 3,4 kg

Interior shelf for tool cabinet RSC50 2.0 A1, with clothes rail

605x596 mm



CONVENIENT CLOTHES RAIL

RSC50 2.0 A1/R59

050001913 3,1 kg

Interior shelf, for tool cabinet RSC50 2.0 A1

605x596 mm

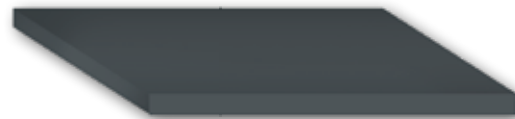

RSC50 2.0 A2

050001412 85 kg

Sheet metal two-door tool cabinet

- 4 removable, vertically adjustable shelves
- With lock
- Interior dimensions: 910x615 mm
- With vertically adjustable feet

CAN BE ACCESSORISED WITH M3CA

70

RSC50 2.0 A2/3C

050001413 105,5 kg

Sheet metal two-door tool cabinet with 3 drawers

- 4 removable, vertically adjustable shelves
- Supplied **complete with 3-drawer** (681x360 mm) module
- Front lock
- Interior dimensions: 910x615 mm
- With vertically adjustable feet

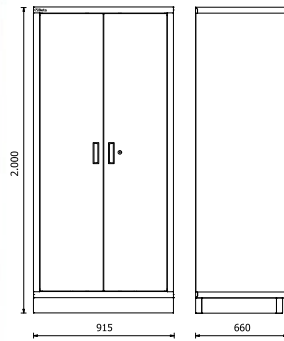

RSC50 2.0 A2/R91

Interior shelf, for tool cabinet RSC50 2.0 A2

050001915 4,2 kg



911x596 mm



Accessories 68

5000 RSC50 2.0/KFC

kit of 10 coloured drawer fronts



1,7 Kg

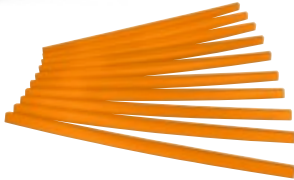

5000 RSC50 2.0/KFC7016

RAL 7016

10x



 050001737

5000 RSC50 2.0/KFC2011

RAL 2011

10x



 050001731

5000 RSC50 2.0/KFC3000

RAL 3000

10x



 050001733

5000 RSC50 2.0/KFC5015

RAL 5015

10x



 050001734

To customize colour of drawer fronts for workshop equipment combination RSC50. Recommended for use in combination with worktops in anthracite grey RAL7016 (-A).

8889P2

 088890107 1,3 kg

Parallel partitions for standard drawer 588x367 mm

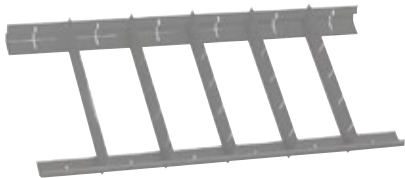

8889C2

 088890117 1,9 kg

Crossed partitions for standard drawer 588x367 mm

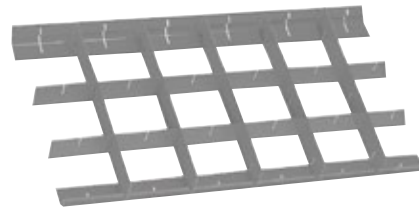

VPM0

 088870350



 147x367 mm

VPM3

 088870353



 147x367 mm

VP3

 088880353



 147x367 mm

VP5

 088880355



 588x122 mm

VP6

 088880359



 588x122 mm

VP4

 088880354



 147x367 mm

1900S 8X10

Automatic hose reel with 8x10 mm hose

- Shockproof plastic body, for air or water
- Max. operating pressure: 15 bar
- Braided polyurethane hose
- Polypropylene frame
- Device for automatically fixing hose at required length
- Rack mechanism can be disabled to keep hose pulled
- Operating temperature range: -5 °C / +50 °C
- Supplied with a 180° swivel bracket and an additional quick connection bracket

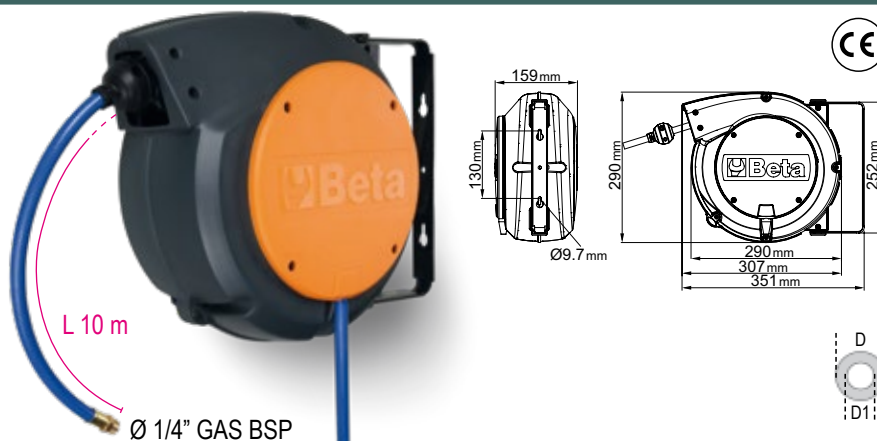

D1	D	L	kg		
Ø 8 mm	Ø 12 mm	10 m	3,9	019000080	

1843 15-H05

Automatic cable reel with 2x1.5 mm² cable

- H05VV-F 2x1,5 mm² cable
- With thermal protection switch
- Coiled cable length: 15 m
- Cable length out of drum: 1 m
- Supplied without incoming cable
- Rack can be disabled to keep cable pulled
- Max. power (rolled up): 1300W (230V-20°C)
- Max. power (unrolled): 2300W (230V-20°C)
- Supplied with a 180° swivel bracket and an additional quick connection bracket

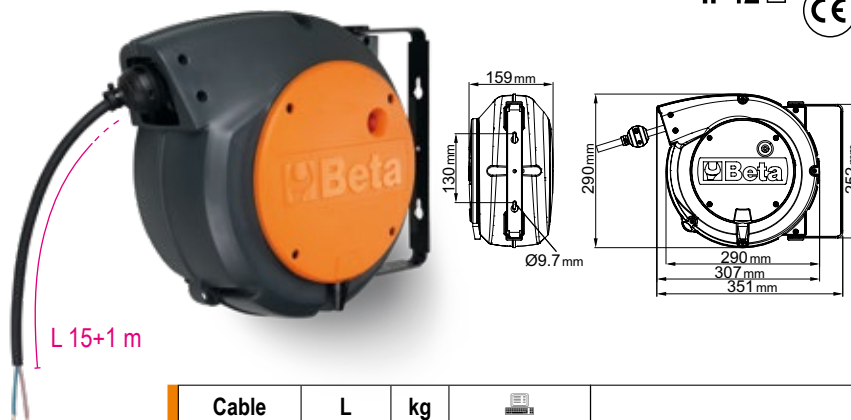

Cable	L	kg			
H05VV-F	15+1 m	4,2	018430215		

1844

Automatic cable reel with 3Gx1,5 mm² cable

- 3Gx1.5 mm² cable
- With thermal protection switch
- Cable length out of drum: 1 m
- Supplied without incoming cable
- Rack mechanism can be disabled to keep cable pulled
- Max. power (rolled up): 1500W (230V-20°C)
- Max. power (unrolled): 2500W (230V-20°C)
- Supplied with a 180° swivel bracket and an additional quick connection bracket

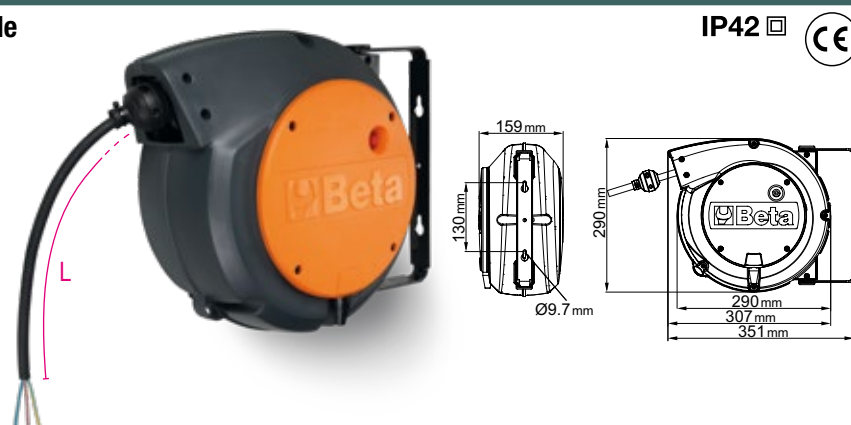

	Cable	L	kg		
1844 10-H05	H05VV-F	10+1 m	3,9	018440310	
1844 15-H05	H05VV-F	15+1 m	4,6	018440315	
1844 15-H07	H07RN-F	14+1 m	5,2	018440317	

1844SCK

Automatic cable reel with 3Gx1.5 mm² cable and SCHUKO type socket

- 3Gx1.5 mm² cable
- With thermal protection switch
- Length of cable out of drum: 1 m
- Supplied with 1.5 m incoming cable and SCHUKO type socket
- Rack mechanism can be disabled to keep cable pulled
- Max. power (rolled up): 1500W (230V-20°C)
- Max. power (unrolled): 2500W (230V-20°C)
- Supplied with a 180° swivel bracket and an additional quick connection bracket



IP42

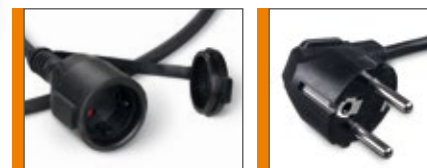
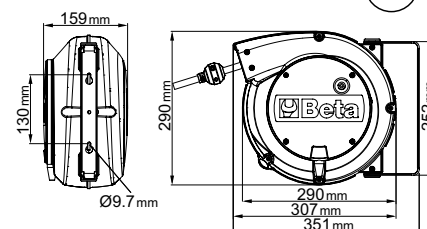

	Cable	L	kg		
1844 15-H05/SCK	H05VV-F	15+1 m	5,0	018440316	
1844 15-H07/SCK	H07RN-F	14+1 m	5,7	018440318	

1845 12-H05

Automatic cable reel with 3Gx2.5 mm² cable

- 3Gx2.5 mm² cable
- With thermal protection switch
- Cable length out of drum: 1 m
- Supplied without incoming cable
- Rack mechanism can be disabled to keep cable pulled
- Max. power (rolled up): 2000W (230V-20°C)
- Max. power (unrolled): 3000W (230V-20°C)
- Supplied with a 180° swivel bracket and an additional quick connection bracket



IP42

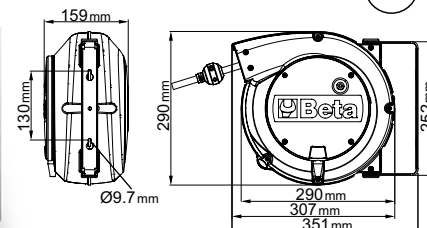

L 12+1 m

	Cable	L	kg		
	H05VV-F	12+1 m	4,9	018450365	

1846

Automatic cable reel with 4Gx1.5 mm² cable

- 4Gx1.5 mm² cable
- Without thermal protection switch
- Cable length out of drum: 1 m
- Supplied without incoming cable
- Rack mechanism can be disabled to keep cable pulled
- Max. power (rolled up): 1400W (400V-20°C)
- Max. power (unrolled): 1900W (400V-20°C)
- Supplied with a 180° swivel bracket and an additional quick connection bracket



IP42

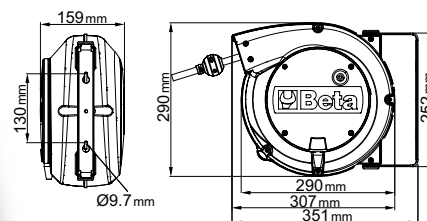

	Cable	L	kg		
1846 10-H05	H05VV-F	10+1 m	4,4	018460405	
1846 10-H07	H07RN-F	10+1 m	5,2	018460407	
1846 15-H05	H05VV-F	15+1 m	5,4	018460415	

Assortment for RSC50 2.0 and C45PRO 2.0

5958U

059581008 11,3 kg

Assortment of 85 tools for universal maintenance

Fixing accessories included.



Assortment recommended in combination with:

RSC50 2.0 - RSC50 2.0 E - RSC50 2.0 F - RSC50 2.0 G - RSC50 2.0 H
 RSC50 2.0 I - RSC50 2.0 L - C45PRO 2.0 D - C45PRO 2.0 F - C45PRO 2.0 G - C45PRO 2.0
 C45PRO 2.0 H - C45PRO 2.0 A - C45PRO 2.0 BP-1,3 - C45PRO 2.0 BP-2,0



OTHER RECOMMENDED ASSORTMENTS IN THE PRICE LIST

Quantity/Description

- 17 combination wrenches 6÷22 mm
- 12 offset hexagon key wrenches \odot 2÷10 mm
- 13 1/2" square drive hexagon sockets with rail \odot 10÷22 mm
- 8 1/2" square drive hexagon sockets with rail \odot 23÷32 mm
- 1 1/2" drive extension bar 125 mm
- 1 1/2" drive extension bar 255 mm
- 1 1/2" drive universal joint
- 1 1/2" drive sliding T-handle
- 1 1/2" drive reversible ratchet \oplus
- 1 circlip pliers straight, internal \odot 180 mm
- 1 circlip pliers straight, external \bullet 175 mm

Beta N.

- 42
- 96N/SC12
- 920A/SB13
- 920A/SB8
- 920/21
- 920/22
- 920/25
- 920/42
- 920/55
- 1032
- 1036

Quantity/Description

- 1 250 mm slip joint plier 1048N
- 1 self - locking pliers 240 mm 1052
- 1 heavy-duty diagonal cutting nippers \nless 160 mm 1084BM
- 1 electrician's scissors, straight blades 1128BMX
- 1 combination plier bi-material \equiv 180 mm 1150BM
- 1 extra-long needle nose pliers \bullet 160 mm 1166BM
- 7 screwdrivers for slotted head screws \bullet 3x75 - 3,5x100 - 4x125 1221
- 5,5x150 - 6,5x150 - 8x200 - 10x200 mm
- 4 screwdrivers for cross head Phillips® screws \oplus PH0x60 1222/S4
- PH1x80 - PH2x100 - PH3x150 mm
- 1 engineer's hammer 300 g 1370
- 1 soft face hammer \emptyset 35 mm 1390
- 1 measuring tape 5 m 1692
- 5 set of 5 second-cut files, with handles 200 mm 1719BMA/S5
- 1 hacksaw frame, aluminium handle 1725
- 1 plastic oil can 150 cc 1754
- 1 snap - off blade utility knife 1771

Assortment for RSC50 2.0 and C45PRO 2.0

5957U-P

059571004 26 kg

Assortment of 133 tools for universal maintenance

Fixing accessories included.



Assortment recommended in combination with:
RSC50 2.0 I - RSC50 2.0 L - C45PRO 2.0 D
C45PRO 2.0 F- C45PRO 2.0 G



Quantity/Description

6	pin punches 2 ÷ 8 mm	31/SP6
6	2 drift punches, 1 centre punch, 3 flat chisels with metal holder	38/SP6
17	combination wrenches 6÷22 - 24 - 27 - 30 mm	42/S17X
12	double open end wrenches 6x7 ÷ 30x32 mm	55/S12X
8	offset hexagon key wrenches 2 ÷ 10 mm	96T/S8
8	offset key wrenches, for Torx® head screws Ⓞ T9 ÷ T40	97TX/SC8
1	Adjustable wrench 250 mm	111E
13	1/2" square drive hexagon sockets with rail Ⓞ 10 ÷ 22 mm	920A/SB13
8	1/2" square drive hexagon sockets with rail Ⓞ 23 ÷ 32 mm	920A/SB8
7	socket drivers for cross head Phillips® screws ●●● 1,2x65 - 1,2x8 - 1,6x9 - 2x12mm - PH1-PH2-PH3	920LH/SB7
1	circlip pliers straight, internal Ⓞ 180 mm	1032
1	circlip pliers bent, internal Ⓞ 170 mm	1034
1	circlip pliers straight, external ● 175 mm	1036
1	circlip pliers bent, external ● 175 mm	1038
1	slip Joint Plier 250 mm	1048N
1	self - locking pliers 240 mm	1052
1	tin snips 250 mm	1112
1	electrician's scissors, straight blades	1128BMX
8	set of screwdrivers 2,5x50 - 3x75 - 4x100 - 5,5x125 - 6,5x150 - PH0 - PH1 - PH2	1223/D8P
2	engineer's hammer 300 - 600 g	1370
1	soft face hammer 35	1390

Quantity/Description

1	measuring tape 5 m	1692/5
1	flexible magnetic pick-up tool	1712E/2
1	two cutting edges scraper 200 mm	1717A
1	three - cutting edges scraper 200 mm	1717B
5	second cut files 200 mm	1719BMA8/S5
1	metal pressure oil can 200 cc	1751N
1	snap - off blade utility knife	1771BM
1	1/2" drive extension bar 125 mm	920/21
1	1/2" drive extension bar 250 mm	920/22
1	1/2" drive universal joint	920/25
1	1/2" drive sliding T-handle	920/42
1	1/2" drive reversible ratchet Ⓞ	920/55
1	pry bar	963
1	diagonal cutting nippers ⚡ 160 mm	1082BM
1	heavy duty diagonal cutting nippers ⚡ 160 mm	1084BM
1	toggle lever assisted end cutting nippers ⚡ 180 mm	1092V
1	Combination plier bi-material ≡ 180 mm	1150BM
1	Extra-long needle nose pliers ● 160 mm	1166BM
1	Extra-long bent needle nose pliers ● 160 mm	1168BM
2	screwdrivers for slotted head screws ● 8x200 - 10x200 mm	1221
1	screwdrivers for cross head Phillips® screws ● PH3 8x150mm	1222
1	sliding gauge 235 mm	1650
1	hacksaw frame, aluminium handle 420 mm	1725

Accessories for RSC50 2.0 and C45PRO 2.0

5000 RSC50 2.0/PLEDC

Aluminium profile with LED strip

- Supplied complete with cables
- Convenient fixing through magnets



050001712 80 g



To be applied under/in suspended cabinets, under shelves and linear guards, to light working areas.

5000 RSC50 2.0/PLEDC-ST **NEW**

Aluminium profile with LED strip and SOFT TOUCH switch

- 6.5W IP20 LED strip; length: 50 cm
- On/off and brightness adjustment SOFT TOUCH switch
- Supplied complete with cables



050001713 80 g

5000 RSC50 2.0/ASL

Power supply, for LED strip

- 24VDC 22W power supply
- Can supply power to up to 3 6.5W LED strips



050001716 210 g



- Convenient fixing through magnets

5000 RSC50 2.0/CTR

LED strip controller, with RF remote control

for workshop equipment combination 5000 RSC50 2.0/PLEDC

Kit contents:

- 1 mini receiver
- 1 wireless RF remote control

Specifications of RF remote control:

- ON/OFF button
- BRIGHT +/- button: allows manual adjustment of lighting power
- 25%/50%/100% button: allows automatic adjustment of lighting power
- Battery: 3V CR2025 (included)

Specifications of mini receiver:

- Input voltage: 5V -24VDC
- Rated output current: 5A
- Peak output current: 12A
- Operating temperature: -20 °C ÷ +35 °C

Integrated features:

- Memory
- Mode (manual/automatic brightness)
- Brightness adjustment



050001721 25 g



		5000 RSC50 2.0/PLEDC-ST	5000 RSC50 2.0/PLEDC	5000 RSC50 2.0/ASL	5000 RSC50 2.0/ASL
	A	1x	-	1x	-
	B	-	1x	1x	1x
	A	1x	1x	1x	-
	B	-	2x	1x	1x
	A	1x	2x	1x	-
	B	-	3x	1x	1x

Accessories and tool hooks RSC50 2.0 and C45PRO 2.0

PM/5C

088880450 1,8 kg

WALL-MOUNTED small parts holder with 5 tote trays, made from plastic, with support

- Interior dimensions: 95x120 mm



600x140x165 mm

PM/6C

088880440 970 g

WALL-MOUNTED small parts holder with 6 tote trays, made from plastic, with support

- Interior dimensions: 80x60 mm



600x95x115 mm

CPMB/3C

088880443 2 kg

Workbench small parts containers with 3 drawers

- Outer frame made of PP
- Small parts drawers made of PET
- Stackable
- Interior drawer dimensions: 160x107x105h mm



600x155x175 mm

Specifications of drawers:

- Unbreakable
- Glass effect transparency unchanged over time
- Scratchproof
- Resistant to oil, acids and aggressive chemicals
- Also suitable for use in food environment



CPMB/5C

088880445 1,5 kg

Workbench small parts containers with 5 drawers

- Outer frame made of PP
- Small parts drawers made of PET
- Stackable
- Interior drawer dimensions: 90x86x62h mm



600x133x132 mm

KIT 6VC/3C

Kit of 6 removable trays for small parts containers CPMB/3C



6x



10x

088880453 830 g

KIT 10VC/5C

Kit of 10 removable trays for small parts containers CPMB/5C

088880455 570 g

CP

088880470 522 g

Wall-mounted bottle holder rack, made of steel



280x95x115 mm

M3CA

088880485 20,5 kg

3-drawer module for two-door tool cabinets C45PRO 2.0 AS2 and RSC50 2.0 A2

- 3 fully removable (661x360 mm), with ball bearing slides
- Drawer height: 78 mm
- Drawer bases protected by foamed rubber mats
- Supplied complete with assembly kit



SP5S

088880475 1,8 kg

Wall-mounted support with 5 compartments

- Made from sheet metal
- 5 tool compartments varying in height



SPC

088880480 1,5 kg

Computer wall bracket

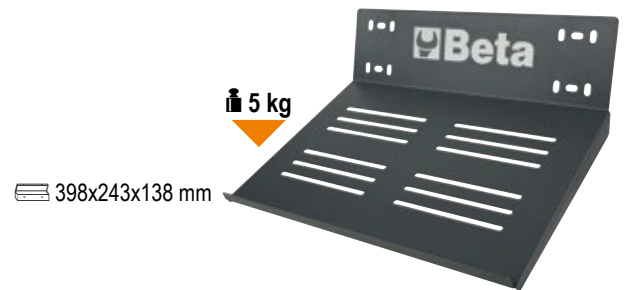

SB

Socket rails



	L mm			
SB1	210	088880201	10pc	
SB2	280	088880202	10pc	
SB3	360	088880203	10pc	

MB

Socket clips for rails SB



MB0	1/4	088880210	50pc	
MB1	3/8	088880211	50pc	
MB2	1/2	088880212	50pc	

GM

Snap hooks with expansion bolts VE1

GM6,5	088880250	5pc	
GM9,5	088880251	5pc	
GM13	088880252	5pc	
GM16	088880253	5pc	
GM19	088880254	5pc	
GM25	088880255	5pc	



KIT/GPS

Kit of 40-mm GPS hooks with screws VE1

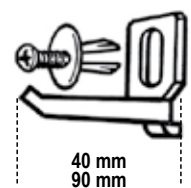

	L			
KIT/GPS-40	40 mm	50pc	088880119	
KIT/GPS-90	90 mm	50pc	088880117	

Accessories for perforated panels RSC50 2.0 and C45PRO 2.0

S55/8

088880420

Supports for 8 double open end wrenches, made from sheet metal

173x113x36 mm

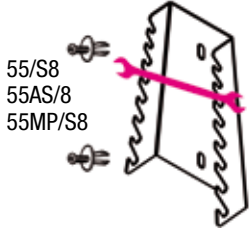

55/S8
55AS/8
55MP/S8

S55/12

088880421

Supports for 12 double open end wrenches, made from sheet metal

286x138x44 mm

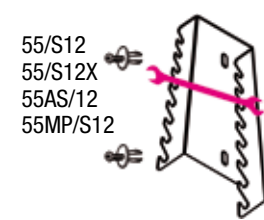

55/S12
55/S12X
55AS/12
55MP/S12

ST2P

088880422

Pliers pockets, made from sheet metal

116x60x31 mm

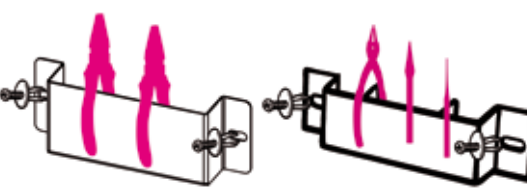

TSP

088880402

Tool pockets, made from plastic material

167x55x16 mm

S952/10

088880423

Supports for 10 T-handles, made from sheet metal

385x97x26 mm

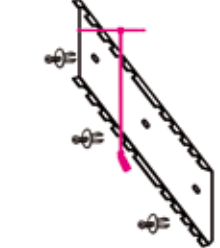

S1719BM

088880404

Supports for 5 files, made from sheet metal

165x48x32 mm



1719BMA: Q-T-P-M-R
1719BMD: Q-T-P-M-R
1719BMX: Q-T-P-M-R

SGN

088880405

Supports for 2 mini screwdrivers, made from sheet metal

60x23x26 mm

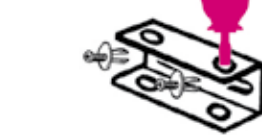

1221N - 1222N - 1229N/PZ
1201EN-1202EN-1209EN/PZ

S42/17

088880428

Supports for 17 combination wrenches, made from sheet metal

577x42 mm

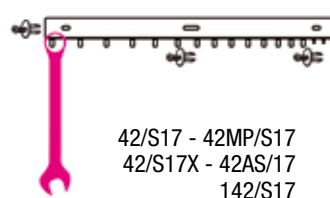

42/S17 - 42MP/S17
42/S17X - 42AS/17
142/S17

S951/6

088880429

Supports for 6 T handle wrenches with hexagon male ends, made from sheet metal

161x50x43 mm

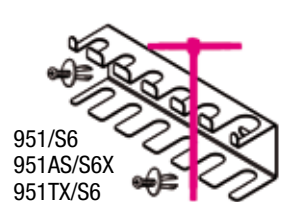

951/S6
951AS/S6X
951TX/S6

SPG11

088880910

Supports for screwdrivers, made from sheet metal

283x49x35 mm

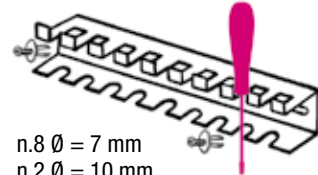

n.8 $\varnothing = 7$ mm
n.2 $\varnothing = 10$ mm
n.1 $\varnothing = 12$ mm

S1203/8

088880430

Supports for screwdrivers, made from sheet metal

283x49x35 mm

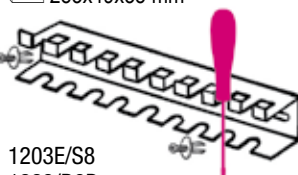

1203E/S8
1223/D8P

S96T/8

088880431

Supports for 8 offset hexagon key wrenches, with high torque handles, made from sheet metal

282x49x45 mm

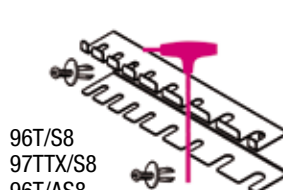

96T/S8
97TTX/S8
96T/AS8

96T/SPV

000960958

Supports for 11 offset hexagon key wrenches, with high torque handles, made from sheet metal

282x49x50 mm

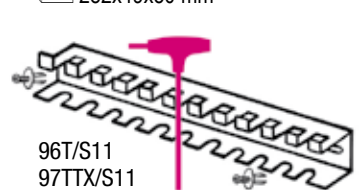

96T/S11
97TTX/S11

3D PLANNER FOR RSC50 2.0 AND C45PRO 2.0

Configure your workshop in 3D online

■ DRAW the walls

Create the walls according to the dimensions of your workshop.

■ DESIGN your workbench system

Select and assemble the component parts, to make your own combination.



■ VIEW the result in 3D

The combination is immediately displayed in 3D and can be viewed from different angles.

■ REQUEST a quote

Print the detail of the arrangement in PDF format and take it to your dealer to get a quote.



CUSTOMIZED MODULES ON REQUEST

Fill your drawers with customized modules in six steps

1

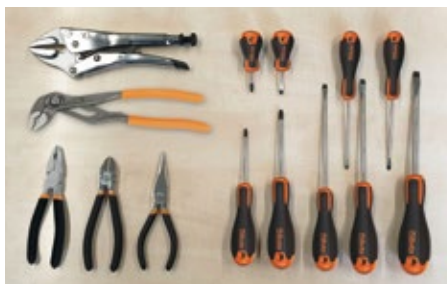

Determine your needs and send your project to the Beta dealer

2

Image	Product	Cod. Beta
	Self-locking pliers	010540022
	Pliers	010470024
	Pliers	011500046
	Screwdrivers for slotted head screws	012011039
	Screwdrivers for cross head Phillips® screws	012021018

We will receive and codify your initial assortment of the project

3

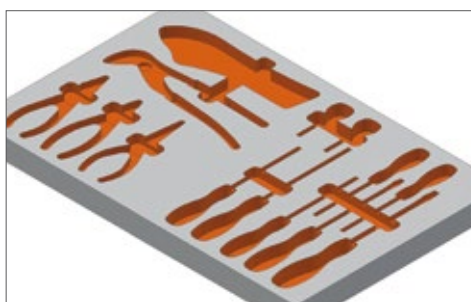

We will execute the design

4

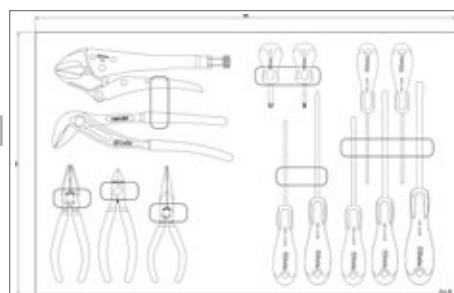

We will submit the final layout for your approval

5



We will build the soft modules in Beta's factory in Sovico

6



We will deliver the tools in the customized modules

Contact our dealer





2025 MOT02
WORLD
CHAMPIONSHIP

CELESTINO VIETTI

ALONSO LÓPEZ

