

# Beta Action 2026



## AUTOMOTIVE

Promotion valid from 02/03/2026 to 31/08/2026  
Prices do not include V.A.T. - Subject to availability

# 2026 1/2

# Beta

RSC 50 2.0



3D  
view

Design your workshop  
**ONLINE CONFIGURATOR**  
Simple, fast and intuitive



<b>2÷7</b>	<b>WORKSHOP EQUIPMENT</b>		<b>40÷45</b>	<b>DIAGNOSTICS</b>	
<b>8÷13</b>	<b>CONTAINERS, WORKBENCHES AND TROLLEYS</b>		<b>46÷48</b>	<b>OIL AND FILTERS</b>	
<b>14-15</b>	<b>ASSORTMENT AND THERMOFORMED TRAYS</b>		<b>49÷51</b>	<b>ENGINE</b>	
<b>16÷18</b>	<b>WRENCHES</b>		<b>52-53</b>	<b>CLEANING</b>	
<b>19</b>	<b>SCREWDRIVERS</b>		<b>53÷58</b>	<b>WHEELS AND BRAKES</b>	
<b>20-21</b>	<b>SOCKETS</b>		<b>58</b>	<b>TRANSMISSION</b>	
<b>22÷24</b>	<b>TORQUE WRENCHES</b>		<b>59</b>	<b>SUSPENSION</b>	
<b>24-25</b>	<b>PLIERS</b>		<b>59÷63</b>	<b>BODYWORK</b>	
<b>25</b>	<b>DRILLING AND THREADING TOOLS</b>		<b>64-65</b>	<b>CAR CARE</b>	
<b>26-27</b>	<b>PULLERS</b>		<b>66÷71</b>	<b>JACKS</b>	
<b>27</b>	<b>HAMMERS AND CHISELS</b>		<b>72</b>	<b>ROBUR</b>	
<b>27-28</b>	<b>GENERAL MAINTENANCE</b>		<b>73</b>	<b>MOTORBIKE REPAIR</b>	
<b>28</b>	<b>MEASURING TOOLS</b>		<b>74</b>	<b>BICYCLE TOOLS</b>	
<b>29</b>	<b>BETA CHEMICALS</b>		<b>75-76</b>	<b>AUTOMOTIVE KIT TYRE KIT</b>	
<b>30-31</b>	<b>LIGHTING</b>		<b>77÷81</b>	<b>PNEUMATIC TOOLS</b>	
<b>32</b>	<b>POWER TOOLS</b>		<b>82÷84</b>	<b>SAFETY FOOTWEAR</b>	
<b>33</b>	<b>REELS</b>		<b>85÷88</b>	<b>WORKWEAR</b>	
<b>34-35</b>	<b>INSULATED TOOLS</b>		<b>89</b>	<b>BETA COLLECTION</b>	
<b>36÷40</b>	<b>BATTERY CHARGERS AND STARTERS</b>				

The images are for reference only. Beta Utensili S.p.A. reserves the right to update and upgrade its product range without notice.

**NEW**

PURCHASE THE WORKSHOP EQUIPMENT COMBINATION, **C45PRO**

46-cm-DEEP WORKTOP WORKSHOP EQUIPMENT COMBINATION **C45PRO**

**C45PRO X/196UT**

045001987

Workshop equipment combination C45PRO comprising the following:

- Stainless steel coated MDF worktop, dimensions 2,040x463 mm (C45PX/3-2.0MT)
- Fixed module with 7 drawers (C45PRO M7)
- Mobile roller cab with 7 drawers (C45PRO C7)
- Fixed service module (C45PRO MS)
- 3 perforated tool panels (C45PRO PF)
- 3 wall-mounted cabinets (C45PRO PM)
- 3 wall brackets, wide type (C45PRO SL)
- 1 wall bracket, narrow type (C45PRO SS)
- Two-door cabinet (C45PRO AS2)



305 kg

2000 mm  
495 mm  
2955 mm



ASSORTMENT OF **196** TOOLS **Beta** WORKER



MMC45-V1 BW



MMC45-V2N BW

100% MADE BY Beta

BETA'S NEW RATCHET

14"  
12"



MMC45-V3 BW

~~£ 6,560.00~~  
**£ 2,450.00**



Save  
**£ 389.00**

Compared to purchases of loose products

**NEW**

# COMPLETE WITH ASSORTMENT THAT BEST CATERS TO YOUR NEEDS!

## 61.5-cm-DEEP WORKTOP WORKSHOP EQUIPMENT COMBINATION **C45PRO 2.0**

**C45PRO 2.0 X/267UT**

045009157

### Workshop equipment combination C45PRO 2.0 comprising the following:

- Stainless steel coated MDF worktop, dimensions 2,040x**615** mm (C45PRO 2.0 PXE/3-2.0MT)
- Fixed module with 7 drawers (C45PRO 2.0 M7)
- Mobile roller cab with 7 drawers (C45PRO 2.0 C7)
- Fixed service module (C45PRO 2.0 MS)
- 3 perforated tool panels (C45PRO 2.0 PF)
- 3 wall-mounted cabinets (C45PRO 2.0 PM)
- 3 wall brackets, wide type (C45PRO 2.0 SL)
- 1 wall bracket, narrow type (C45PRO 2.0 SS)
- Two-door cabinet (C45PRO 2.0 AS2)



334 kg

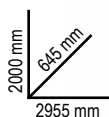

## ASSORTMENT OF **267** TOOLS **Beta** WORKER



BW MVC45-1/VA



BW MVC45-2/VA



BW MVC45-3/VA



BW MVC45-4/VA



BW MVC45-5/VA

~~£ 7,760.00~~  
**£ 2,830.00**



Save  
**£ 744.00**  
Compared to purchases of loose products



**BETA'S NEW RATCHET**



**NEW**

PURCHASE THE WORKSHOP EQUIPMENT COMBINATION, **C45PRO 2.0**

**C45PRO 2.0 B7X/196UT**

045009155



• **Stainless steel coated MDF worktop**, dimensions 1,360x615 mm (C45PRO 2.0 PXE/2-1.3MT)

211 kg

**C45PRO 2.0 B7W/196UT**

045009156



• **Multi-ply wood worktop**, dimensions 1,360x615 mm (C45PRO 2.0 PWE/2-1.3MT)

201 kg

**Workshop equipment combination C45PRO 2.0 comprising the following:**

- Fixed module with 7 drawers (C45PRO 2.0 M7)
- Fixed two-door module (C45PRO 2.0 MA)
- 2 wall-mounted cabinets (C45PRO 2.0 PM)
- 2 perforated tool panels (C45PRO 2.0 PF)
- 2 wall brackets, wide type (C45PRO 2.0 SL)
- 1 wall bracket, narrow type (C45PRO 2.0 SS)
- Single-door cabinet (C45PRO 2.0 AS1)

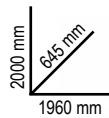

**61.5-cm-DEEP WORKTOP**



**ASSORTMENT OF 196 TOOLS** **Beta** WORKER



MMC45-V1 BW



MMC45-V2N BW



MMC45-V3 BW



BETA'S NEW RATCHET



14"  
12"

~~£ 5,020.00~~  
**£ 1,895.00**



Save  
**£ 274.00**

Compared to purchases of loose products

**NEW**

**COMPLETE WITH ASSORTMENT THAT BEST CATERS TO YOUR NEEDS!**

**C45PRO 2.0 AX/157UT**

045009167



• **Stainless steel coated MDF worktop**, dimensions 2,040x615 mm (C45PRO 2.0 PXE/3-2.0MT)

234,5 kg

**C45PRO 2.0 AW/157UT**

045009168



• **Multi-ply wood worktop**, dimensions 2,040x615 mm (C45PRO 2.0 PWE/3-2.0MT)

219 kg

**Workshop equipment combination C45PRO 2.0 comprising the following:**

- Fixed service module (C45PRO 2.0 MS)
- Fixed module with 7 drawers (C45PRO 2.0 M7)
- Fixed two-door module (C45PRO 2.0 MA)
- 3 wall-mounted cabinets (C45PRO 2.0 PM)
- 3 perforated tool panels (C45PRO 2.0 PF)
- 2 wall brackets, narrow type (C45PRO 2.0 SS)
- 2 wall brackets, wide type (C45PRO 2.0 SL)

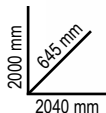

**61.5-cm-DEEP WORKTOP**



**ASSORTMENT OF 157 TOOLS**



**FIXED ACCESSORIES INCLUDED**



~~£ 5,170.00~~  
**£ 2,170.00**



**Save £ 209.00**  
Compared to purchases of loose products



**BETA'S NEW RATCHET**

KUP ZESTAW MEBLI WARSZTATOWYCH  
**RSC50 2.0**



**RSC50 2.0 D/223UT**

050001092



- Blat roboczy 1495x700 mm (RSC50 2.0 NPG/2-1.5MT)

276 kg

**RSC50 2.0 DX/223UT**

050001082



- Blat roboczy (1,495x700 mm) z płyty MDF pokrytej stalą nierdzewną (RSC50 2.0 PX/2-1.5MT)

275 kg

**NEW**

Zestaw mebli warsztatowych systemu RSC50 2.0

- Moduł stały z 7 szufladami (RSC50 2.0 M7)
- Moduł stały dwudrzwiowy (RSC50 2.0 MA)
- 2 szafki wiszące (RSC50 2.0 PM)
- 2 górne panele perforowane na narzędzia (RSC50 2.0 PFS)
- 2 dolne panele perforowane na narzędzia (RSC50 2.0 PFI)
- 2 pary prawych/lewych wspomników (RSC50 2.0 P/2MDX-SX)
- Szafa jednodrzwiowa (RSC50 2.0 A1)

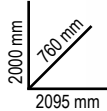

70-cm-GŁĘBOKI BLAT ROBOCZY



ZESTAW **223** NARZĘDZI I AKCESORIÓW **Beta**



M301

26



M306MH

153

14"

12"

100%  
MADE  
By  
Beta



NOWE WZORNICTWO  
GAMY POKRĘTEL ZAPADKOWYCH



M311MH

29



M304

15

~~44.820,00 zł~~  
**16.900,00 zł**

**OSZCZĘDZASZ  
5.894,00 zł**  
W PORÓWNANIU DO ZAKUPU PRODUKTÓW



# COMPLETE WITH ASSORTMENT THAT BEST CATERS TO YOUR NEEDS!

## RSC50 2.0 F/445UT

050001096



• Worktop 2,240x700 mm made from **sheet metal** (RSC50 2.0 NPG/3-2.2MT)

411 kg

## RSC50 2.0 FX/445UT

050001086



• Worktop 2,240x700 mm made from **stainless steel coated MDF** (RSC50 2.0 PX/3-2.2MT)

405 kg

**NEW**

Workshop equipment combination RSC50 2.0 comprising the following:

- 1 fixed module with 7 drawers (RSC50 2.0 M7)
- 1 mobile roller cab with 7 drawers (RSC50 2.0 C7)
- 1 fixed service module with 2 drawers (RSC50 2.0 MS-2C)
- 3 wall-mounted cabinets (RSC50 2.0 PM)
- 3 upper perforated tool panels (RSC50 2.0 PFS)
- 3 lower perforated tool panels (RSC50 2.0 PFI)
- 3 pairs of right/left uprights (RSC50 2.0 P/2MDX-SX)
- 1 two-door cabinet (RSC50 2.0 A2)



2000 mm  
760 mm  
3155 mm

## ASSORTMENT OF 445 TOOLS FOR AUTOMOTIVE **Beta**



M105MH

116

14"  
38"  
12"



M158MH

161

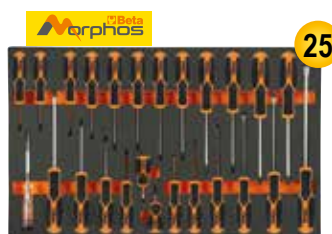

M195MH

25



M266

55



M25

40



M304

15



M118

33



REVERSIBLE  
IMPACT WRENCH  
1927P

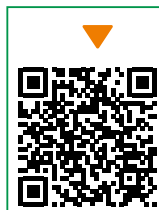

~~£ 15,950.00~~  
**£ 5,480.00**



Save  
**£ 1,758.00**  
Compared to purchases of loose products

# RSC RANGE

## THE EVOLUTION OF PERFECTION



kg  
800

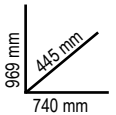

### RSC24

Mobile Roller cab, empty

- ABS reinforced worktop
- Multi-purpose top with anti-fall edges and eight holes for accommodating screwdrivers
- 4 castors Ø 125 mm: 2 fixed and 2 steering (one with brake)
- Front centralized safety lock
- Built-in bottle holder (can be applied on both sides).
- Drawer bases protected by foamed rubber mats
- Each drawer can accommodate up to 4 EVA foam or ABS thermoformed trays



	kg	Ral 2011 Ral 7016	Ral 3000 Ral 7016	Ral 7016	Ral 2011	Ral 9006 Ral 7016	Ral 5015 Ral 7016	Ral 9005	£
<b>RSC24/7</b>	63	024004071	024004073	024004077	024004070	024004072	024004076	024004079	<del>£ 1,071.00</del> <b>£ 595.00</b>
<b>RSC24/5</b>	60	024004051	024004053	024004057	<del>£ 924.00</del> <b>£ 499.00</b>				
<b>RSC24/6</b>	62	024004061	024004063	024004067	<del>£ 996.00</del> <b>£ 559.00</b>				
<b>RSC24/8</b>	66	024004081	024004083	024004087	<del>£ 1,161.00</del> <b>£ 649.00</b>				

**2400 RSC24/7-VAS/FO** >>> 024004048 <<<

**2400 RSC24/7-VAS/A** >>> **NEW** 024004043 <<<

Assortment of **223** tools for AUTOMOTIVE 14" 12"

Medium version



M301

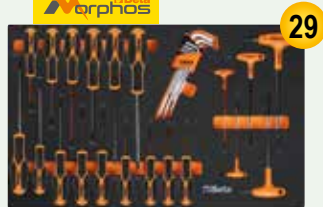

M311MH



M304



M306MH

**INCLUDED:**  
**MOBILE ROLLER CAB RSC24/7**



**2400 RSC24/7-VAS/FO**

024004048



**2400 RSC24/7-VAS/A**

024004043

**NEW**



Save up to **£ 1,840.00**

THE MOST COMPLETE **Beta** ASSORTMENT EVER  
**AND THE ROLLER CAB RSC24 IS INCLUDED IN THE PRICE!**







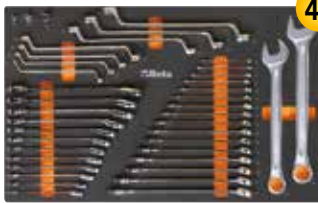

**THE MOST COMPLETE BETA ASSORTMENT EVER**

**2400 RSC24/8-VAL/O** >> 024004007 <<

**2400 RSC24/8-VAL/A** >> **NEW** 024004026 <<

~~£ 5,930.00~~  
**£ 1,895.00**

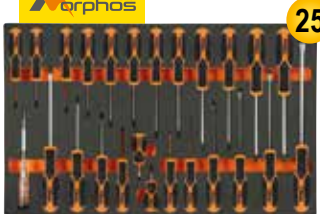
Assortment of **445** tools for AUTOMOTIVE **14"** **38"** **12"**

 <b>M25</b>	 <b>M304</b>	 <b>M118</b>	 <b>REVERSIBLE              IMPACT WRENCH              1927P</b>
 <b>M105MH</b>	 <b>M158MH</b>	 <b>M195MH</b>	 <b>M266</b>



**2400 RSC24/8-VAL/O**  
 024004007



**2400 RSC24/8-VAL/A**  
 024004026  
**NEW**

**Extra large version**

**INCLUDED:  
 MOBILE ROLLER CAB  
 RSC24/8**

- 8 removable drawers (588x367 mm), with ball bearing slides
- 6 drawers, 70 mm high
- 2 drawers, 140 mm high

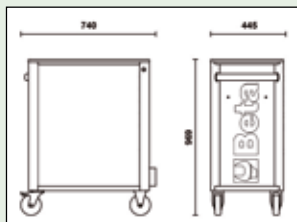

**Save up to £ 4,035.00**

## RSC24AXL

### Mobile roller cab, WITH ANTI-TILT SYSTEM, long model

- New ABS reinforced worktop with anti-fall edges, eight holes for accommodating screwdrivers and 6 tote trays
- **Sturdy nylon front, with built-in label holder**
- Drawer bases protected by foamed rubber mats
- 4 castors, Ø 125 mm: 2 fixed and 2 steering (one with brake)
- Front centralized safety lock
- Built-in side bottle holder (can be applied on both sides)
- **Each drawer can accommodate up to 6 EVA foam or ABS thermoformed trays**

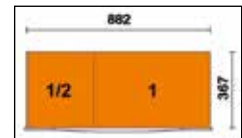

	Ral 2011	Ral 3000	Ral 7016	n°	Max	kg	£
	Ral 7016	Ral 7016	Ral 7016				
RSC24AXL/7	024004271	024004273	024004277	5	70 mm	30 kg	84 <del>£ 1,595.00</del> £ 849.00
				1	140 mm	35 kg	
				1	210 mm	35 kg	
RSC24AXL/8	024004281	024004283	024004287	6	70 mm	30 kg	88 <del>£ 1,618.00</del> £ 919.00
				2	140 mm	35 kg	
				8	70 mm	30 kg	
RSC24AXL/9	024004291	024004293	024004297	8	70 mm	30 kg	90 <del>£ 1,715.00</del> £ 975.00
				1	140 mm	35 kg	

## RSC28

### SuperTank trolley with wood worktop and 10 drawers

- 10 drawers (588x367 mm) with ball bearing slides
- Quick, safe system for opening and closing drawers, with nylon and fibreglass front
- Drawer bases protected by foamed rubber mats
- 4 high-capacity castors, Ø 150 mm: 2 fixed and 2 steering with brakes
- 2 centralized safety locks
- Multi-ply wood worktop with holes for a vice (1599F/150 - 1599GI/150, to be ordered separately)
- 4 bottle holders (2 front and 2 rear)
- 6 side tote trays
- Side compartment with foldaway door with lock
- 135-mm-high storage compartment with plastic-covered base

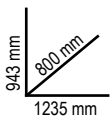

	Ral 2011	Ral 7016	Ral 3000	n°	Max
	028003001	028003007	028003003	8	70 mm 25 kg
				2	210 mm 30 kg

- 5 side drawers:**
- 4 drawers, 70 mm high
  - 1 drawer, 210 mm high
- 5 front drawers:**
- 4 drawers, 70 mm high
  - 1 drawer, 210 mm high



## RSC24AXXL

### Mobile roller cab with 8 drawers and anti-tilt system, long model

- 1 fully removable drawer (1,176x367 mm), with ball bearing slides
- 7 fully removable drawers (882x367 mm), with ball bearing slides:
  - 6 drawers 70 mm high
  - 1 drawer 140 mm high
- **Worktop made from stainless steel coated MDF**, with holes for vice item 1599F/125 or 1599GI/125 (to be ordered separately) and 6 tote trays
- Sturdy nylon fronts, with built-in label holders
- Drawer bases protected by foamed rubber mats
- Removable side compartment, with ball bearing slides, with shelf and lock
- 4 castors, Ø 150 mm: 2 fixed and 2 steering with brakes
- 3 safety locks
- Built-in paper roll holder
- Built-in bottle holder
- Following trays can be added: **up to 8 EVA foam or ABS thermoformed trays in drawer 1,176x367 mm**  
**up to 6 EVA foam or ABS thermoformed trays in drawer 882x367 mm**

£ 2,140.00  
**£ 1,219.00**

kg  
**1100**



kg **131**

1020mm  
550mm  
1330mm

### YOUR WORKSHOP ON WHEELS



Ral 2011 Ral 3000 Ral 7016  
Ral 7016 Ral 7016  
024004781 024004783 024004787



n°		kg Max
1	70 mm (1.176x367 mm)	40 kg
6	70 mm (882x367 mm)	30 kg
1	140 mm (882x367 mm)	35 kg



## C45PRO 2.0 MWS

### Work Station roller cab with 7 drawers and built-in waste bin

- 1 drawer (1248x406 mm) with ball bearing slides
- 6 drawers (782x406 mm) with ball bearing slides:
  - 5 drawers 65 mm high
  - 1 drawer 145 mm high
- Drawer bases protected by foamed rubber mats
- Can be fitted with thermoformed trays
- Storage compartment with intermediate shelf and door, interior dimensions 504x424x597 mm
- Built-in waste bin
- Built-in paper roll compartment
- 4 heavy-duty castors, Ø 150 mm, 2 fixed and 2 steering with brakes
- Front centralised lock
- Can accommodate a vice (1599P/150, to be ordered separately)



1042mm  
463mm  
1780mm

n°		kg Max
5	65 mm	25 kg
1	105 mm	40 kg
1	145 mm	30 kg

## C45PRO 2.0 MWS/X

045000181



- Worktop (1680 mm) made of **stainless steel coated MDF**

£ 1,730.00  
**£ 940.00**

kg **126**

## C45PRO 2.0 MWS/W

045000191



- **Multi-ply wood** worktop (1680 mm)

£ 1,685.00  
**£ 940.00**

kg **122**

**C51**

**Trolley**

- 3 tops covered in antislip ribbed rubber
- Two fixing options for central worktop
- Four castors Ø 100 mm: 2 fixed and 2 steering (1 with brake)

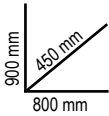

**C25** 025000001

**Tank trolley with shelf**

- Foldaway lid
- 1 sliding drawer
- Tool tray protected by foamed rubber mats
- Shelves protected by oil and fuel proof mats
- Four castors 100 mm in Ø: 2 fixed and 2 swivelling (one with brake)
- Safety lock
- One more shelf M4 can be added on the opposite side.
- Empty thermoformed tray for 1/2" sockets and accessories (024990104)
- Paper roll holder item 2499PC can also be included (to be ordered separately)

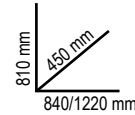

**3069** 030690000

**Manual pallet truck**



**Features:**

- 2 steering wheels, 200x50 mm, made of PU
- Double front rollers, 80x70 mm, made of PU
- Pallet access entry and exit rollers
- Depth stop notch
- Lowering speed control valve
- Safety overload valve
- **3-position operating lever**

**Technical data:**

- Maximum capacity: 2500 kg
- Overall length: 1550 mm
- Fork length: 1150 mm
- Fork width: 540 mm
- Individual fork width: 160 mm
- Lever height: 1230 mm
- Max. lifting height: 115 mm
- Pallet storage corridor: 800x1200 lengthwise: 1805 mm
- Turning radius: 1347 mm

~~£ 770.00~~  
**£ 339.00**



**C56**

**Workbench**

- Worktop made of painted sheet metal with external edge
- Steel frame with 6 supporting legs
- Static load capacity: 1200 kg
- Matches panel toolholder C57P; cannot be fixed to worktop
- Two drawers with lock
- Can be fixed to floor



# MODULAR *line*

## RANGE OF WORKBENCHES



### C58BC-W2,1 4CA+SVR LED

Workbench, 2.1 m long, with wood worktop, 4 drawers and door module

~~£ 2,205.00~~  
£ 1,229.00

- Multi-ply wood worktop (2,100x750 mm), 38 mm thick
- 4 drawers (367x588 mm) with ball bearing slides:
  - 2 drawers 70 mm high
  - 2 drawers 140 mm high.
- Drawer bases protected by foamed rubber mats
- Each drawer can accommodate up to 4 EVA foam or ABS thermoformed trays
- Front centralized lock
- 1 door module with lock
- Steel frame with 4 supporting legs
- Holes for a vice (1599F/150 - 1599GI/150, to be ordered separately)
- 2 lower half-shelves for objects, 1,788x335 mm, 40 mm thick
- Static load capacity: 800 kg, uniformly distributed
- Can be fixed to floor
- Kit with 4 perforated tool panels
- 2 LED lamp tracks IP20



Ral 2011	Ral 7016
Ral 7016	
058000743	058000748

NEW

### C58BC-2,1

Simple workbench, 2.1 m long

- Steel frame with 4 supporting legs
- Holes for a vice (1599F/150 - 1599GI/150, to be ordered separately)
- Lower half-shelf for objects, 1,788x335 mm; thickness: 40 mm
- Can be fixed to floor



### C58BC-W2,1

058000621



~~£ 679.00~~  
£ 375.00

- Worktop (2,100x750 mm) made from multi-ply wood, 38 mm thick

### C58BC-X2,1

058000626



~~£ 708.00~~  
£ 375.00

- Worktop (2,100x750 mm) made from stainless steel coated MDF, 38 mm thick

**5904VA/T**

059040416

**Assortment of 102 tools in foam trays**

12

~~£ 1,786.00~~  
**£ 965.00**

Quantity/Description	Beta N.	TR
21 combination wrenches 6-7-8-9-10-11-12-13-14-15-16-17-18-19-20-21-22-24-27-30-32 mm	42	T05
8 double open end wrenches 6x7-8x9-10x11-12x13-14x15-16x17-18x19-20x22 mm	55	T06
9 offset hexagon key wrenches $\varnothing$ 1,5+10 mm	96/SC9	T33
6 offset hexagon key wrenches with handles $\varnothing$ 2-2,5-3-4-5-6 mm	96T	T52
8 T - handle wrenches with swivelling socket $\varnothing$ 7-8-10-12-13-14-17-19 mm	952	T63
19 1/2" square drive hexagon sockets $\varnothing$ 10-11-12-13-14-15-16-17-18-19-20-21-22-23-24-26-27-30-32 mm	920A	T83
1 1/2" drive extension bar 125 mm	920/21	T83
1 1/2" drive extension bar 255 mm	920/22	T83
1 1/2" drive universal joint	920/25	T83
1 1/2" drive sliding T-handle 305 mm	920/42	T83
1 1/2" drive reversible ratchet $\odot$	920/55	T83
1 heavy-duty diagonal cutting nippers $\nlessdot$ 160 mm	1084BM	T137
1 combination pliers bright chrome-plated, bi-material handles $\equiv$ 180 mm	1150BM	T137
1 Extra-long needle nose pliers $\bullet$ 160 mm	1166BM	T137
1 circlip pliers straight, internal $\odot$ 180 mm	1032	T145
1 circlip pliers bent, internal $\odot$ 170 mm	1034	T145
1 circlip pliers straight, external $\bullet$ 175 mm	1036	T145
1 circlip pliers bent, external $\bullet$ 175 mm	1038	T145
1 self - locking pliers 240 mm	1052	T153
1 slip joint pliers, slip-proof PVC coated handles 250 mm	1048N	T153
7 screwdrivers for slotted head screws $\bullet$ 2,5x50 - 3x75 - 3,5x100 - 4x125 - 5,5x100 - 5,5x150 - 6,5x150 mm	1221	T199MH
6 screwdrivers for cross head Phillips <sup>®</sup> screws $\oplus$ PH0x60 - PH0x100 - PH1x80 - PH1x120 - PH2x100 - PH2x150 mm	1222	T202MH
2 flat chisels, ribbed type 100-200 mm	35	T234
1 engineer's hammer 300 g	1370	T234
1 soft face hammer $\varnothing$ 35 mm	1390	T234
1 empty thermoformed tray	VP5	

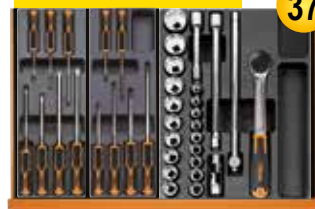

T199MH T202MH

37



T145 T153 T137 T234

13



T52 T33 T05 T06

44



T63 VP5

8

**Recommended with: RSC23T - RSC24 - RSC24A - RSC24AXL - RSC24AXLP/7 - RSC24AXXL - RSC24L/7 - RSC24-CAB - C37 - C39 - C39SM - C39MD - RSC28 - C59 - C58BC - RSC55 - RSC50 2.0**

**M01**

024500001



22

~~£ 441.00~~  
**£ 249.00**

**4,5 kg**

42 6-7-8-9-10-11-12-13-14-15-16-17-18-19-20-21-22-24-27-30-32-36 mm

**M05**

024500005



16

~~£ 217.00~~  
**£ 122.00**

**1,5 kg**

42 6-7-8-9-10-11-12-13-14-15-16-17-18-19-20-21 mm

**M45**

024500045



12

~~£ 319.00~~  
**£ 176.00**

**1,3 kg**

142 8-9-10-11-12-13-14-15-16-17-18-19 mm

**M46**

024500046



12

~~£ 376.00~~  
**£ 194.00**

**1,4 kg**

142SN 8-9-10-11-12-13-14-15-16-17-18-19 mm

**M50**

024500050



8

~~£ 129.50~~  
**£ 72.90**

**1,1 kg**

96T  $\varnothing$  2-2,5-3-4-5-6-7-8 mm

**M63**

024500063



8

~~£ 342.00~~  
**£ 197.00**

**3,4 kg**

$\varnothing$  952 7-8-10-12-13-14-17-19 mm

**M69**

024500069

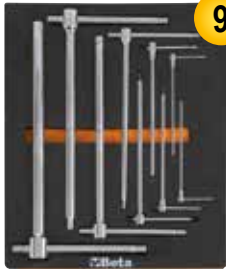

9

~~£ 294.00~~  
**£ 164.00**

**1,8 kg**

$\varnothing$  951 2,5-3-4-5-6-8-10-12-14 mm

**M100MH** >> 024500109 <<

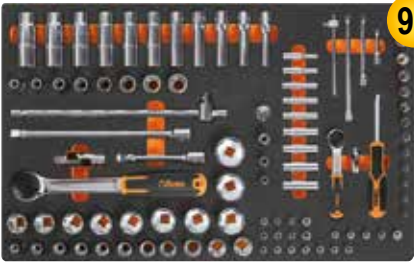

**98** ~~£1,198.00~~  
**£ 569.00**

📦 6,7 kg >> **14" 12"**

- 895/1 - 895/3 - 895/6
- 900 4-4,5-5-5,5-6-7-8-9-10-11-12-13-14 mm
  - 900L 5-6-7-8-9-10-11-12-13 mm
  - 900ME 3-4-5-6-7 mm
  - 900LP 0,8x4-1x5,5-1,2x6,5-1,2x8 mm
  - ⊕ 900PH PH1-PH2-PH3-PH4
  - ⊕ 900TX T10-T15-T20-T25-T27-T30-T40
  - 900/20 50 mm - 900/20L 100 mm
  - 900/21 150 mm
  - 900/25
  - 900BG/31
  - 900/42

- ⊗ 900/55
- 920A 8-10-11-12-13-14-15-16-17-18-19-20-21-22-23-24-26-27-28-30-32 mm
- 920/15 - 920/25
- 920AN/125 125 mm
- 920AN/250 250 mm
- 920/42
- ⊗ 920/55
- ⊕ 920FTX 10-12-14-16-18-20-22-24 mm
- 920AL 10-12-13-14-15-16-17-18-19-21-22 mm

**NEW**

**M105MH** >> 024500114 <<



**116** ~~£1,388.00~~  
**£ 615.00**

📦 7,7 kg >> **14" 38" 12"**

- 900 4-4,5-5-5,5-6-7-8-9-10-11-12-13-14 mm
- 900L 5-6-7-8-9-10-11-12-13 mm
- 96BPC/SC9 1,5-2-2,5-3-4-5-6-8-10 mm
- 895/1 - 895/3 - 895/6
- 900ME 3-4-5-6-7 mm
- 900LP 0,8x4-1x5,5-1,2x6,5-1,2x8 mm
- ⊕ 900PH PH1-PH2-PH3-PH4
- ⊕ 900TX T10-T15-T20-T25-T27-T30-T40
- 900/16 □ 1/4 - ■ 3/8
- 900/... 50-100-150 mm
- 900/25 - 900BG/31 - 900/42
- ⊗ 900/55
- 910A 6-7-8-9-10-11-12-13-14-15-16-17-18-19-20-21-22 mm
- 910/15 □ 3/8 - ■ 1/4

- 910/16 □ 3/8 - ■ 1/2
- 910/21 125 mm
- 910/22 250 mm
- 910/25 - 910/42
- ⊗ 910/55
- 920A 8-10-11-12-13-14-15-16-17-18-19-20-21-22-23-24-26-27-28-30-32 mm
- 920/15 □ 1/2 - ■ 3/8
- 920/25
- 920AN 125 - 250 mm
- 920/42
- ⊗ 920/55
- 956E 16-17,8-20,8 mm

**NEW**

**M118** >> 024500118 <<



**33** ~~£ 987.00~~  
**£ 469.00**

📦 8 kg >> **12"**

FOR 140 MM DRAWERS

- 1927P 1750 Nm
- 720L ○ 13-17-19-21-22-24 mm
- 720ME ○ 5-6-8-10-12-14-17-19 mm
- 720 ○ 10-12-13-14-15-16-17-18-19-21-22-24-27-30-32 mm
- 720LC ○ 17-19-21 mm

**M125** >> 024500872 <<



**68** ~~£1,250.00~~  
**£ 569.00**

📦 7,9 kg >> **38" 12"**

- 910AL 8-9-10-11-12-13-14-15-16-17-19-21-22 mm
- 920PE 5-6-6L-7-8-8L-10-10L-12-12L mm
- 920FTX E12-E14-E16-E18-E20-E22-E24
- ⊕ 920TX T20-T25-T27 -T30-T30L-T40-T40L-T45-T50-T50L-T55-T60-T60L
- 920XZN 5-6-6L-8-8L-10-10L-12L mm
- ⊕ 900TX T10-T15-T20-T25-T27-T30-T40
- 920AL 10-12-13-14-15-16-17-18-19-21-22-23-24-27-30-32 mm
- 1692/5 5 m

**M195MH** >> 024500196 <<

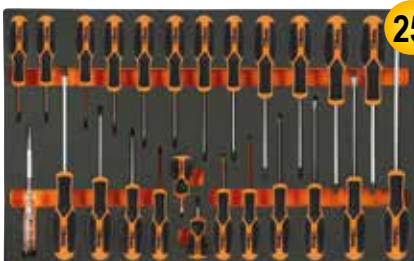

**25** ~~£ 363.00~~  
**£ 197.00**

📦 3,4 kg >>

- 1253 3,5x100 mm
- 1221 2,5x50 - 3x75 - 4x100 - 5,5x125 - 6,5x150 - 8x200 mm
- 1222 PH0x60 - PH1x80 - PH2x100 - PH3x150 mm
- ⊕ 1222N PH1X30 mm
- 1227TX T6-T7-T8-T9-T10-T15-T20-T25-T27-T30-T40-T45
- 1221N 4x30 mm

**NEW**

**M213** >> 024500213 <<

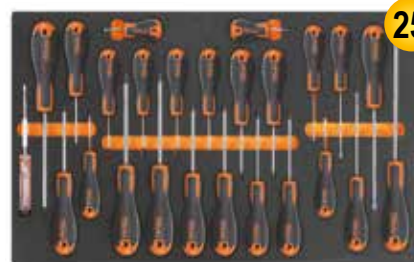

**25** ~~£ 217.00~~  
**£ 126.00**

📦 1,8 kg >>

- 1201E 2,5x50-3x75-4x100-5,5x125-6,5x150-8x200 mm
- 1201EN 4x30 mm
- ⊕ 1202E PH0x60-PH1x80-PH2x100-PH3x150 mm
- ⊕ 1202EN PH1X30 mm
- 1207E/TX T6-T7-T8-T9-T10-T15-T20-T25-T27-T30-T40-T45
- 1253 3,5x100 mm

**M230** >> 024500230 <<



**25** ~~£ 414.00~~  
**£ 235.00**

📦 3,2 kg >>

- 30 Ø 2-3-4 mm
- 31 Ø 2-3-4-5-6-8 mm
- 32 Ø 4 mm
- 34 150 mm
- 35 200-250 mm
- 36 125 mm
- 1370 500 g
- 1390 Ø 35 mm
- 1692 3 m
- 1712
- 1719BMA/Q 200 mm
- ▲ 1719BMA/T 200 mm
- 1719BMA/P 200 mm
- ▶ 1719BMA/M 200 mm
- 1719BMA/R 200 mm
- 1737NX
- 1771 170 mm

42

# BETA'S ICONIC WRENCH

A STYLISH, SLIM SHAPE ENHANCED BY A SLENDER PROFILE, LIGHTER TO THE TOUCH



## 42/SC8

Set of 8 combination wrenches with compact support

000421086

£ 102.50  
£ 59.90

NEW SUPPORTS

8-10-12-13-14-15-17-19 mm



NEW

## 42/SP15

Set of 15 combination wrenches

000421078

£ 192.50  
£ 106.00

• Supplied with a comfortable, practical holder

6-7-8-9-10-11-12-13-14-15-16-17-19-22-24 mm



## 142/SC8

Set of 8 reversible ratcheting combination wrenches, with compact support

001420086

£ 200.00  
£ 113.00

NEW SUPPORTS

8-10-12-13-14-15-17-19 mm



NEW

## 42/S26

Set of 26 combination wrenches

000421070

£ 444.00  
£ 249.00

6-7-8-9-10-11-12-13-14-15-16-17-18-19-20-21-22-23-24-25-26-27-28-29-30-32 mm



## 142SN/SC8

Set of 8 swivel end ratcheting combination wrenches, with compact support

001420258

£ 239.00  
£ 138.00

NEW SUPPORTS

8-10-12-13-14-15-17-19 mm



NEW

## 55/B12N

Set of 12 double open end wrenches in roll-up wallet made of durable polyester

000550164

£ 148.50  
£ 87.00

6x7-8x9-10x11-12x13-14x15-16x17-18x19-20x22-21x23-24x26-25x28-30x32 mm



**90/B8N**

000900156

Set of 8 double ended deep offset ring wrenches in roll-up wallet made of durable polyester

~~£ 125.00~~  
**£ 72.90**

6x7-8x9-10x11-12x13-14x15-16x17-18x19-20x22 mm



**96T/55P**

000960946

Set of 5 offset hexagon key wrenches with handles

~~£ 64.00~~  
**£ 36.00**

Ø 2,5-3-4-5-6 mm



**141/B9**

001410069

Set of 9 ratcheting combination wrenches, straight series in wallet

~~£ 198.50~~  
**£ 87.00**

8-10-11-12-13-14-15-17-19 mm



**97TTX/56**

000970791

Set of 6 ball head offset key wrenches for Torx® head screws with handles

~~£ 91.00~~  
**£ 48.00**

Ø T10-T15-T20-T25-T30-T40



**186 8-32**

001860008

Self-locking wrench with automatic take-up device for hexagons, 8 to 32 mm

~~£ 49.00~~  
**£ 28.50**

Ideal for hexagon, Spline, square and Torx® head screws, including damaged screws

**L 260 mm**



SPLINE®  
12 sides

Square

Torx®

Hexagonal

Rounded bolt  
70%

**951GP/56**

009511687

Set of 6 T-handle wrenches with one hexagon male end

~~£ 161.00~~  
**£ 75.90**

Ø 3-4-5-6-8-10 mm



**951/56** >> 009510687 <<

Set of 6 T-handle wrenches with three hexagon male ends

£ 129.50  
£ 72.90

○ 2,5-3-4-5-6-8 mm



**952/07** >> 009520079 <<

Set of 7 T-handle wrenches with swivelling hexagon sockets

£ 250.00  
£ 144.00

○ 7-8-10-12-13-14-17 mm

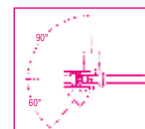
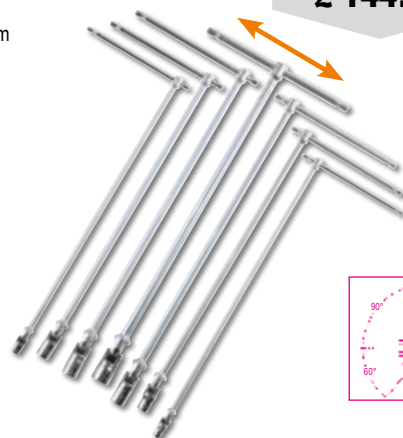

**920/40** >> 009200850 <<

1/2" drive swivel T-handle

£ 59.50  
£ 33.90

12"

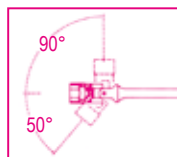

L mm	A mm
490	230

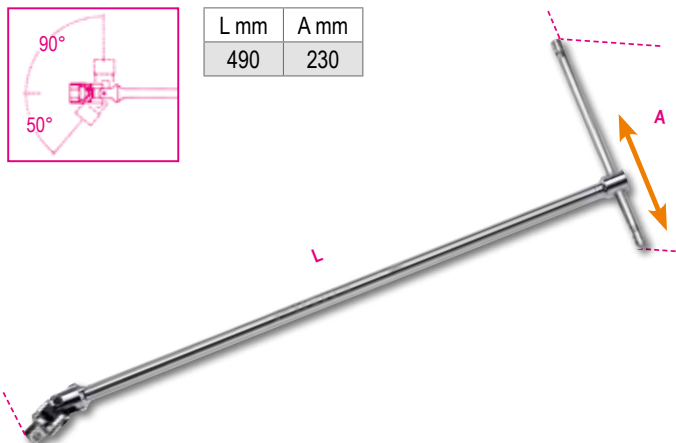

**96BP-H0/SC9** >> 000961254 <<

Set of 9 ball head offset hexagon key wrenches, with screw holding system

£ 47.50  
£ 22.90

○ mm	L mm
1,5	79
2	84
2,5	89
3	99
4	100
5	126
6	148
8	168
10	187

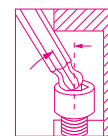

**96BPC/SC9** >> 000960354 <<

Set of 9 ball head offset hexagon key wrenches

£ 44.00  
£ 22.50

○ mm	L mm
1,5	79
2	84
2,5	89
3	99
4	108
5	126
6	148
8	168
10	187



**97BTX/SC8** >> 000970164 <<

Set of 8 ball head offset key wrenches, long model, for Torx® head screws

£ 77.00  
£ 42.50

○ mm	L mm
T9	62
T10	71
T15	81
T20	92
T25	94
T27	105
T30	114
T40	129



**97BRTXL/SC8** >> 000970464 <<

Set of 8 ball head offset key wrenches, long model, for Tamper Resistant Torx® head screws

£ 93.00  
£ 43.50

⊕ mm	L mm
T9	80
T10	86
T15	100
T20	110
T25	126
T27	140
T30	160
T40	176

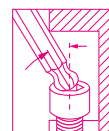

EXTRA LONG VERSION +25%





# THE SCREWDRIVER THAT ADAPTS TO THE SHAPE OF YOUR HAND

## 1 HANDLE

The handle relies on an innovative **THREE-MATERIAL FRAME**: the polypropylene body ensures firmness, whereas an **INNER ULTRASOFT TPR layer**, placed at the points of contact with the palm, is **SUBJECT TO CONTROLLED DEFORMATION**, in order to adapt to the hand and provide **IMPROVED TRANSMISSION AND COMFORT**.

2 Triangular section for **reduced rolling on worktop**

3 Relief texture for **improved grip** – for example, under the toughest work conditions

4 Immediate blade identification on head

5 Black phosphated tip for more accurate coupling with the screw and improved wear resistance



## TORQUE

In-house laboratory tests have shown the ability to transmit

**MORE THAN 30% ADDITIONAL TORQUE COMPARED TO THE PREVIOUS MODELS.**

**REDUCED EFFORT AND HIGHER PERFORMANCE IN EACH APPLICATION**

**NEW**



**1223/DBP**  
 > 012230018 <

Set of 8 screwdrivers  
~~£ 69.00~~  
**£ 39.50**

1221 ● 2,5x50 - 3x75 - 4x100 - 5,5x100 - 6,5x150 mm  
 1222 ● PH0x60 - PH1x80 - PH2x100

**1223/D10N**  
 > 012230019 <

Set of 10 screwdrivers  
~~£ 86.50~~  
**£ 50.50**

1221 ● 2,5x50 - 3x75 - 4x100 - 5,5x150 - 6,5x150 mm  
 1221N ● 4x30 mm  
 1222 ● PH0x60 - PH1x80 - PH2x100  
 1222N ● PH1

**1227TX/D7**  
 > 012270207 <

Set of 7 screwdrivers  
~~£ 88.50~~  
**£ 51.00**

1207E/TX ● T5 - T6 - T8 - T10 - T15 - T20 - T25

**NEW**

**1203E/DBP**  
 > 012031018 <

Set of 8 screwdrivers  
~~£ 43.50~~  
**£ 25.50**

1201E ● 2,5x50 - 3x75 - 4x100 - 5,5x100 - 6,5x150 mm  
 1202E ● PH0x60 - PH1x80 - PH2x100 mm

**1203E/D10N**  
 > 012031019 <

Set of 10 screwdrivers  
~~£ 55.50~~  
**£ 31.90**

1201E ● 2,5x50 - 3x75 - 4x100 - 5,5x150 - 6,5x150 mm  
 1202E ● PH0x60 - PH1x80 - PH2x100 mm  
 1201EN ● 4x30 mm  
 1202EN ● PH1x30 mm

**1207E/TX-D7**  
 > 012071207 <

Set of 7 screwdrivers  
~~£ 56.00~~  
**£ 31.90**

1207E/TX ● T6 - T8 - T10 - T15 - T20 - T25 - T30



**THE EVOLUTION OF THE SCREWDRIVER!**



867/C52

008670901

52 hexagon bits, 10 mm and 2 accessories



£ 139.50  
£ 77.50

- 867PE ○ 4-5-6-7-8-10-12 mm
- 867PE/L ○ 4-5-6-7-8-10-12 mm
- 867XZN ○ M5-M6-M8-M10-M12
- 867XZN/L ○ M5-M6-M8-M10-M12
- 867TX ⊕ T20-T25-T30-T40-T45-T50-T55
- 867TX/L ⊕ T20-T25-T30-T40-T45-T50-T55
- 867RTX ⊕ T20-T25-T30-T40-T45-T50-T55
- 867RTX/L ⊕ T20-T25-T30-T40-T45-T50-T55
- 867/1 ○ 10 mm - □ 3/8"
- 867/2 ○ 10 mm - □ 1/2"



52x

2,1 kg

250x170x70 mm

920TX/SB9

009200532

Set of 9 socket drivers for Torx® head screws on support

£ 175.50  
£ 96.50

- ⊕ T20-T25-T27-T30-T40-T45-T50-T55-T60



900/C11

009000971

11 hexagon sockets, 20 bits and 8 accessories, in metal case

- |  |           |        |
|--|-----------|--------|
| 861LP ● 0,5x3-0,8x5,5-1x5,5-1,2x6,5 mm | 900/20    | 50 mm  |
| 861PE ○ 3-4-5-6-8 mm                   | 900/21    | 150 mm |
| 861PH ⊕ PH0-PH1-PH2-PH3                | 900/25    |        |
| 861TX ○ T8-T10-T15-T20-T25-T30-T40     | 900/42    |        |
| 895/1 ○ 1/4" - □ 1/4"                  | 900BG/31  |        |
| 900 ○ 5-5,5-6-7-8-9-10-11-12-13-14 mm  | 900/55N ⊕ |        |
| 900/16 □ 1/4 - ■ 3/8"                  |           |        |



39x

£ 225.50  
£ 130.00



350x150x50 mm

1,2 kg

902A/C22

009020807

Assortment of 22 hexagon sockets and 6 accessories, in metal case

- |             |   |  |
|-------------|---|--|
| <b>1/4"</b> | 900 ○ 5-5,5-6-7-8-9-10-11-12-13 mm            |  |
|             | 900/20 ○ 50 mm                                |  |
|             | 900/25  |  |
|             | 900/55 ⊕                                      |  |
| <b>1/2"</b> | 920A ○ 10-13-14-15-17-18-19-22-24-27-30-32 mm |  |
|             | 920/21 ○ 125 mm                               |  |
|             | 920/25  |  |
|             | 920/55 ⊕                                      |  |



28x

£ 361.00  
£ 205.00



420x185x60 mm

3,5 kg

920A/C17M

009200924

Assortment of 17 hexagon sockets and 5 accessories in foam tray, in metal case

£ 322.00  
£ 185.00

- 920A ○ 10-11-12-13-14-15-16-17-18-19-20-21-22-24-27-30-32 mm
- 920/21 125 mm
- 920/22 255 mm
- 920/25
- 920/42 305 mm
- 920/55 ⊕



22x

420x185x60 mm

928A/C12

009280955

Assortment of 12 hexagon hand sockets and 5 accessories, in metal case

£ 855.00  
£ 485.00

- 928A ○ 22-24-27-30-32-34-36-38-41-46-50-55 mm
- 928/21 200 mm
- 928/22 380 mm
- 928/25
- 928/42 450 mm
- 928/55 ⊕



17x

530x220x80 mm

13,5 kg

# BETA'S RANGE OF RATCHETS

BETA'S RANGE OF RATCHETS HAS BEEN CHANGED AND EXPANDED:  
CHOOSE THE MODEL THAT SUITS YOUR NEEDS BEST!



Ratchet with up to **72 teeth: take-up angle of 5°** for jobs in small spaces. 17-tooth serration, including 11 always in grip.



Minimum head size for easier access. Phosphated square drive.



One-handed reversal.



Hand pressure on the ratchet head does not cause any accidental reversal or release of the socket.

The versions with 1/2" and 3/4" square drives rely on approximately 6% weight reduction, for optimal handling and increased ease of use, without affecting sturdiness or performance.

## NEW DESIGN INNOVATIVE MATERIALS FOR TOP PERFORMANCE

### STRAIGHT LEVER

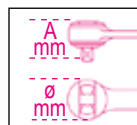

	L mm	Ø mm	A mm	■	Teeth	📄	£
<b>900/55</b>	127	25	29	1/4"	48	009001155	<del>£ 47.00</del> <b>£ 26.50</b>
<b>910/55</b>	207	31	33	3/8"	72	009101155	<del>£ 58.50</del> <b>£ 28.50</b>
<b>920/55</b>	271	40	41	1/2"	72	009201155	<del>£ 61.50</del> <b>£ 33.90</b>
<b>928/55</b>	504	58	59	3/4"	72	009281155	<del>£ 161.50</del> <b>£ 93.00</b>

- 1** Straight lever: the pressing process originates from a semi-finished product with a round cross-section, specially designed to minimise inner tension, thus resulting in optimal performance.
- 2** Slim, ergonomic bi-material handle.
- 3** Hanging hole on handle.

### BENT LEVER

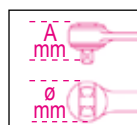

	L mm	Ø mm	A mm	■	Teeth	📄	£
<b>900E/55</b>	125	26	25	1/4"	48	009001255	<del>£ 47.00</del> <b>£ 26.50</b>
<b>910E/55</b>	204	31	33	3/8"	72	009101255	<del>£ 58.50</del> <b>£ 28.50</b>
<b>920E/55</b>	267	40	41	1/2"	72	009201255	<del>£ 61.50</del> <b>£ 33.90</b>

## EASY ACCESS TO SMALL SPACES



- 1** Bent lever with raised handle compared to worktop, for increased comfort and ease of use in small spaces.
- 2** Slim, ergonomic bi-material handle.
- 3** Hanging hole on handle.

**NEW**

560/C6

005600160

Torque multipliers for right-hand and left-hand tightening in plastic case



£ 923.00  
£ 515.00

Complete with straight reaction lever and reaction foot

Nm	kgfm	lbf.ft	□	■	kg
1500	150	1106	1,2"	3/4"	6

RATIO: 6.5:1

599DGT-AW

Electronic torque wrench, torque and angle readout, with reversible ratchet and wireless data transmission, right-hand (accuracy: ± 2%) and left-hand (accuracy: ± 3%) tightening

UNI EN ISO 6789

14" 38" 12" CE

- Tightening types: torque, angle, torque + angle
- Dual measurement mode: peak hold and track
- Light indicators, an intermittent sound and tactile feedback inform user that preset torque or angle has been reached
- Last 999 peak torque and/or angle readings can be stored and displayed
- 9 "Preset" modes can be saved and preset
- Key safety lockout
- Wrench can be associated with a certain user via software
- Tightening data traceability. Software allows date and time, tool serial number, set tightening value and reached value to be stored and associated with user ID

- Nonslip bi-material handle
- Wrench + software in 9 languages
- Included: 3 AA - 1.5V batteries, wireless USB key and software USB key
- **Bi-directional wireless data transmission, from wrench to software and vice versa, in mass a posteriori or in real time**
- **Customized data processing software with immediate, easy-to-read OK/NG result and real time display of charts**



TORQUE + ANGLE

	Nm	kgfm	lbf.ft	■	L (mm)		g	📡	£
<b>599DGT-AW/30</b>	6÷30	0,6÷3	4,5÷22	1/4"	410	0,1	800	005990702	<del>£ 1,105.00</del> <b>£ 625.00</b>
<b>599DGT-AW/135</b>	27÷135	2,7÷13,5	20÷100	3/8"	445	1,0	1000	005990713	<del>£ 1,122.00</del> <b>£ 635.00</b>
<b>599DGT-AW/340</b>	68÷340	6,8÷34	50÷250	1/2"	615	1,0	1500	005990734	<del>£ 1,195.00</del> <b>£ 655.00</b>



610L

Click-type torque wrenches with L-shaped levers, for right-hand tightening, with 5 preset values, torque accuracy: ± 4%

12"



L mm	L1 mm
470	80

UNI EN ISO 6789

610L/5

006100125

Selectable torque values 90-100-110-120-130 Nm

£ 173.50  
£ 93.50

610L/5L

006100150

Selectable torque values 120-140-160-180-200 Nm

£ 179.00  
£ 97.00

**610X/4**

006100200

Cross torque wrench, has been specially designed for tyre shops; for right-hand tightening with 4 preset

Torque values:  
90 - 100 - 110 - 120 Nm

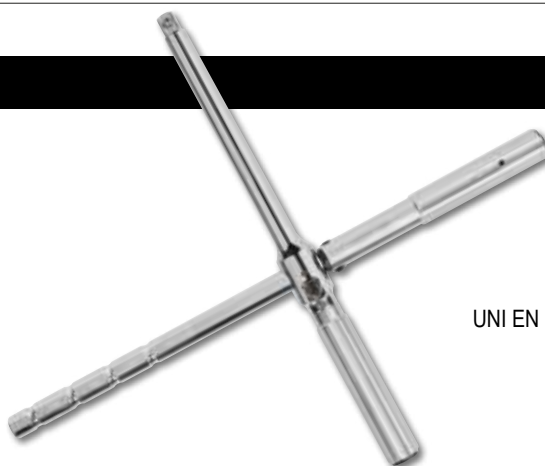

12"

UNI EN ISO 6789



~~£ 142.00~~  
**£ 80.50**

**NEW**

**666**

ZERO-RESET click-type torque wrenches with reversible ratchets, for right-hand tightening, torque accuracy: ± 3%



TORQUE WRENCH **ZERO-RESET** THAT DOES NOT REQUIRE RELEASING TENSION



	Nm	■	▤	L (mm)	g		£
666/2	5÷25	1/4"	0,05	273	395	006660702	<del>£ 296.00</del> <b>£ 160.00</b>
666/2X	5÷25	3/8"	0,05	273	405	006660703	<del>£ 296.00</del> <b>£ 160.00</b>
666/5	10÷50	3/8"	0,25	342	680	006660705	<del>£ 261.00</del> <b>£ 147.00</b>
666/10	20÷100	3/8"	0,25	385	760	006660710	<del>£ 262.00</del> <b>£ 148.00</b>
666/10X	20÷100	1/2"	0,25	385	770	006660711	<del>£ 267.00</del> <b>£ 151.00</b>
666/20	40÷200	1/2"	0,5	471	1020	006660720	<del>£ 285.00</del> <b>£ 158.00</b>
666/30	60÷300	1/2"	1	600	1271	006660730	<del>£ 323.00</del> <b>£ 180.00</b>

UNI EN ISO 6789

1/4" 3/8" 1/2"



**666/C20**

006661020

ZERO-RESET click-type torque wrenches, in metal case, 16 pieces, with sockets and extension bars

- 666/20 40÷200 Nm
- 920A 13÷27 mm
- 920/20-920/21-920/22 75-125-255 mm
- 920/15 □ 1/2" - ■ 3/8"



16x

~~£ 485.00~~  
**£ 269.00**

12"

510x180x45 mm

**NEW**

**667**

ZERO-RESET click-type torque wrenches with push-through ratchets, for right-/left-hand tightening, torque accuracy: ± 3%

DOES NOT REQUIRE RELEASING TENSION

UNI EN ISO 6789

12" 3/4"

	Nm	■	▤	L (mm)	g		£
667/20	40÷200	1/2"	0,5	471	1035	006670720	<del>£ 289.00</del> <b>£ 157.00</b>
667/30	60÷300	1/2"	1,0	600	1285	006670730	<del>£ 312.00</del> <b>£ 171.00</b>
667/40	80÷400	3/4"	1,0	710	2220	006670740	<del>£ 750.00</del> <b>£ 419.00</b>

677/C

Break-back torque wrenches with push-through ratchets, for right-hand and left-hand tightening, torque accuracy:  $\pm 4\%$  in case

The break-back torque wrench, Beta 677, is particularly suitable for heavy-duty use at high torques.



The break-back mechanism informs the user that the set torque has been reached through the bending of the wrench at the joint by approximately 20°.



3/4"

UNI EN ISO 6789

	Nm	kgfm	lbf.ft	■	▬▬▬	L (mm)	kg	006770607	£
677/C600	120÷600	12÷60	100÷450	3/4"	10	1059	6,0	006770607	<del>£ 1,144.00</del> £ 649.00
677/C800	200÷800	20÷80	150÷600	3/4"	10	1319	6,7	006770612	<del>£ 1,191.00</del> £ 669.00
677/C1000	300÷1000	30÷100	200÷750	3/4"	20	1554	7,4	006770616	<del>£ 1,265.00</del> £ 710.00

601C

006010100

Digital angle indicator

- For tightening screws to values set by measuring torsion angle
- Complete with buzzer and LED indicators informing user that preset angle has almost or finally been reached
- For right-hand and left-hand tightening
- Angle accuracy:  $\pm 2^\circ$
- Resolution:  $0.1^\circ$
- Up to 9 angle values can be preset
- Up to 50 measurements can be stored
- Supplied in an ABS case
- Power supply: 2 AAA-size batteries (included)

~~£ 218.50~~  
£ 126.00



601CA

006010120

Digital torque and angle indicator

- Allows torque and angle tightening
- For right-hand and left-hand tightening
- Reading scale in Nm/ft.lb/in-lb/kg.cm/degrees
- Torque accuracy:  $\pm 4\%$  of set value - Angle accuracy:  $\pm 2^\circ$
- Complete with buzzer and LED indicators informing use that preset angle or torque has almost or finally been reached
- Up to 9 torque or angle values can be preset
- Up to 50 measurements can be stored
- Power supply: 2 AAA-sized batteries (included)

~~£ 387.00~~  
£ 219.00



□	■	Nm	▬▬▬
1/2"	1/2"	40÷200	0,1



1009L/DP-S2

010090060

Set of 2 extra-long, knurled double swivel nose pliers

L 340 mm

~~£ 77.50~~  
£ 44.50



1169BM/D3

011690133

Set of 1 combination pliers, 1 long needle nose pliers and 1 diagonal cutting nippers

~~£ 100.50~~  
£ 57.00



1166BM 160 mm

1150BM 180 mm

1082BM 160 mm

# 1047N

**THE SLIP JOINT PLIERS WITH PUSH BUTTON ALIGNMENT WITH EXCLUSIVE JAW ADJUSTMENT AND AUTOMATIC LOCKING SYSTEM**

- 1** Tapered head for easier access to small areas
- 2** Induction hardened teeth for increased durability. Tooth geometry and angle designed for effective, safe hold.
- 3** Adjustable up to 23 positions in the 250-mm-long size
- 4** Ease of handling and comfort, based on the triangular section of the handles, for an enlarged contact surface and reduced applied work effort
- 5** Nonslip PVC coated handles



DIN ISO 8976



**PATENTED MECHANISM FOR JAW ADJUSTMENT AND AUTOMATIC LOCKING**



The exclusive push button system allows the pliers to be opened, closed and used with one hand.



**1047N 250**

010470024

L mm	A Max mm	L1 mm	S mm	g
250	42	37	8	394

~~£ 55.00~~  
**£ 30.00**

**NEW**

## 1031/S4

010310000

Set of 4 circlip pliers

~~£ 115.00~~  
**£ 64.50**



1032 180 mm  
⊙ 19 ÷ 60 mm

1036 175 mm  
● 19 ÷ 60 mm

1038 175 mm  
● 19 ÷ 60 mm

1034 170 mm  
⊙ 19 ÷ 60 mm

## 437U/09

004370050

Assortment for repairing damaged threads, in metal case

~~£ 351.00~~  
**£ 199.00**

M5X0,8  
M6X1,0  
M8X1,25  
M10X1,5  
M12X1,75



370x230x55 mm

## 446/C110

004460060

Assortment of 105 chrome-steel taps and dies, metric thread, and 5 accessories for car repair jobs, in wooden case

~~£ 900.00~~  
**£ 485.00**

430 M mm	433 M mm	440/440A M mm	441/441A M mm
2x0,4	6x0,75 - 7x0,75	2x0,4	6x0,75 - 7x0,75
3x0,5	8x0,75 - 8x1	3x0,5	8x0,75 - 8x1
4x0,7	9x0,75 - 9x1	4x0,7	9x0,75 - 9x1
5x0,8	10x0,75 - 10x1	5x0,8	10x0,75 - 10x1
6x1	10x1,25 - 11x0,75	6x1	10x1,25 - 11x0,75
7x1	11x1 - 11x1,25	7x1	11x1 - 11x1,25
8x1,25	12x0,75 - 12x1	8x1,25	12x0,75 - 12x1
9x1,25	12x1,25 - 12x1,5	9x1,25	12x1,25 - 12x1,5
10x1,5	14x1 - 14x1,25	10x1,5	14x1 - 14x1,25
11x1,5	14x1,5 - 16x1	11x1,5	14x1,5 - 16x1
12x1,75	16x1,5 - 18x1,5	12x1,75	16x1,5 - 18x1,5
14x2		14x2	
16x2		16x2	

435/0 444/1 436/1  
435/3 444/2



500x337x60 mm

**1430/S5** >> << 014300105 <<

Set of 5 tapered extractors for broken screws and studs, made from hardened steel, in case

~~£ 26.50~~  
**£ 15.50**

M3÷M18  
1430/1-1430/2-1430/3  
1430/4-1430/5



**1433/C11** >> << 014330311 <<

Set of 11 roller stud extractors with 1/2" female square and hexagon drives, in metal case with soft thermoformed tray

~~£ 269.00~~  
**£ 155.00**

**3/8" 12"**

- 19 mm (M5)
- 21 mm (M6-M7-M8-M9-M10-M10,5-M11-M12)
- 24 mm (M14-M16)

≡ 340x135x56 mm



**1545/C5M** >> << 015450011 <<

Puller 1542/1 with 5 extractors 1544

~~£ 569.00~~  
**£ 319.00**

	A mm	C mm
1544/1	9÷12	0,80
1544/2	13÷17	1,15
1544/3	16÷21	1,70
1544/4	20÷25	1,65
1544/5	25÷30	2,00

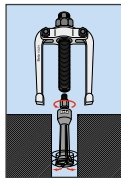

≡ 265x180x45 mm

**1548/C6** >> << 015480306 <<

Bearing removal tool with thin interchangeable terminals

~~£ 569.00~~  
**£ 329.00**

Bearings:

1548/1 6011-6020, 6206-6218, 62/28, 6303-6313, 63/22, 63/28, 6403-6410

1548/2 6000-6010, 6200-6205, 62/22, 6300-6302, 16002, 16003, 16011, 16100, 16101

● 19 mm



≡ 420x185x60 mm



**NEW**

**1500** >>

Two-leg universal pullers

- For both external and internal use
- Legs can be moved along crosspiece with stop nuts

	A min÷max mm	L mm	L1 mm	● mm	A1 min÷max mm	015000301	£
1500/1	25÷80	100	135	17	70÷130	015000301	<del>£ 87.00</del> <b>£ 50.90</b>
1500/2	25÷130	100	135	17	80÷180	015000302	<del>£ 91.00</del> <b>£ 52.50</b>
1500/3	50÷160	150	210	22	105÷220	015000303	<del>£ 151.50</del> <b>£ 87.50</b>
1500/4	60÷200	150	210	22	120÷270	015000304	<del>£ 208.00</del> <b>£ 120.00</b>
1500/5	80÷250	205	280	27	160÷330	015000305	<del>£ 378.00</del> <b>£ 220.00</b>
1500/6	80÷320	205	280	27	160÷420	015000306	<del>£ 444.00</del> <b>£ 260.00</b>
1500/7	110÷520	205	280	27	195÷600	015000307	<del>£ 663.00</del> <b>£ 379.00</b>
1500/8	170÷640	230	310	36	260÷715	015000308	<del>£ 1,062.00</del> <b>£ 615.00</b>

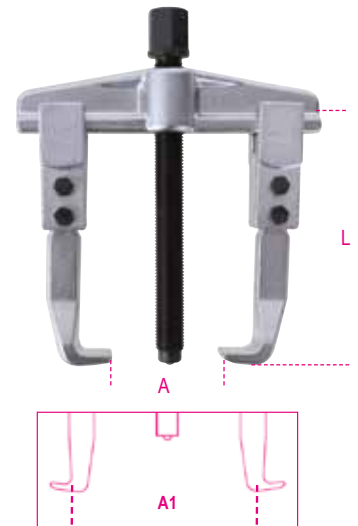

**1428/SB11**

014280111

Set of pullers for damaged nuts square drive with support

38" 12"

~~£ 238.00~~  
**£ 112.00**

8-10-11-12-13-14-15-16-17-18-19 mm



**31/B6N**

000310024

Set of 6 pin punches in roll-up wallet made of durable polyester

~~£ 68.50~~  
**£ 38.50**

2-3-4-5-6-8 mm



**35/S4**

000350506

Set of 4 ribbed chisels L=150-200-250-300 mm

~~£ 133.00~~  
**£ 76.00**



**963**

009630001

Pry bar with pointed and flat bent ends

~~£ 38.00~~  
**£ 21.90**

400 mm



**965 450**

009650014

Pry bars with flat curved ends

~~£ 24.90~~  
**£ 14.00**

450 mm



**1370**

Engineers' hammers wooden shaft

HICKORY



UNI 7778 DIN 1041

	g	g		£
1370/300	300	439	013700053	<del>£ 15.90</del> <b>£ 9.50</b>
1370/500	500	669	013700055	<del>£ 19.40</del> <b>£ 11.00</b>
1370/800	800	949	013700058	<del>£ 25.50</del> <b>£ 14.50</b>
1370/1000	1000	1180	013700060	<del>£ 30.00</del> <b>£ 17.50</b>
1370/1500	1500	1722	013700065	<del>£ 34.50</del> <b>£ 20.00</b>
1370/2000	2000	2181	013700070	<del>£ 41.00</del> <b>£ 23.90</b>

**1390**

Soft face hammers, wooden shaft



UNI 7784

	mm	g		£
1390/22	22	134	013900022	<del>£ 19.40</del> <b>£ 11.00</b>
1390/28	28	230	013900028	<del>£ 24.10</del> <b>£ 14.00</b>
1390/35	35	365	013900035	<del>£ 32.50</del> <b>£ 19.00</b>
1390/45	45	689	013900045	<del>£ 52.00</del> <b>£ 30.00</b>
1390/60	60	1462	013900060	<del>£ 88.00</del> <b>£ 51.50</b>

**1599F**

Parallel bench vices, forged

Fully steel cast.

- Milled and hardened jaw surface
- Front opening
- High clamping depth

	L mm	BxH mm	mm	A max mm		£
1599F/100	100	92x46	11	125	015990100	<del>£ 336.00</del> <b>£ 194.00</b>
1599F/125	125	108x54	13	150	015990125	<del>£ 429.00</del> <b>£ 239.00</b>
1599F/150	150	125x62	13	200	015990150	<del>£ 604.00</del> <b>£ 339.00</b>
1599F/175	175	140x70	15	220	015990175	<del>£ 823.00</del> <b>£ 465.00</b>



1712E

Flexible magnetic pick up tools



	L mm	D mm	F kg	W g		£
1712E/1	420	7,5	0,5	145	017120021	<del>£ 32.00</del> £ 18.00
1712E/2	530	15	1,8	232	017120022	<del>£ 41.00</del> £ 21.90
1712E/3	532	19	3,0	239	017120023	<del>£ 50.50</del> £ 25.50

NEW

1750KG10

017500100

Lever-operated grease gun, 10 kg, with high-pressure hose, 2 m

~~£ 199.00~~  
£ 114.00

3 different pressure levels available:  
- 4 g at 275 bar  
- 7 g at 206 bar  
- 9 g at 137 bar



1750

017500500

Lever operated grease guns, 500 cc

~~£ 44.00~~  
£ 25.50



550 BAR

1650

Sliding gauge made from hardened stainless steel

- Reading to 0.05 mm
- Spring locking

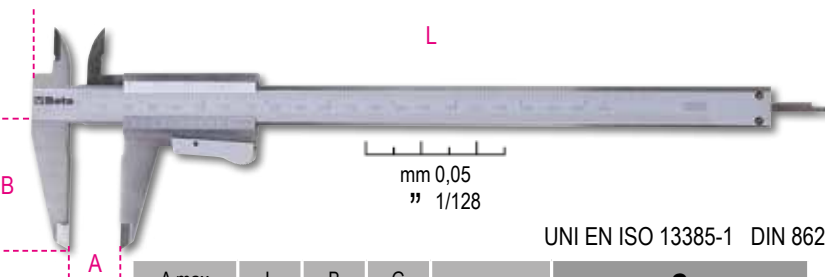

UNI EN ISO 13385-1 DIN 862

	A max mm	L mm	B mm	G mm		£
1650 150	12÷140	145	250	18	016500001	<del>£ 62.50</del> £ 36.50
1650 200	20÷180	200	300	18	016500002	<del>£ 83.00</del> £ 47.90

1706DGT

017060011

Digital depth gauge for tyre threads

~~£ 38.00~~  
£ 19.50



mm 0,01  
" 0,001

L mm	A Max mm	L1 mm
112,5	25	60

1760TMC

017600710

Infrared thermal camera

Compact thermal camera for contactless temperature measurement, suitable for applications in building, mechanical, electric installation and heating industries.

TEMPERATURE RANGE FROM -20 ÷ +600 °C



IP54



- LCD TFT display, 2", 240x320
- Sensor, 32x32 pixels
- Acquisition frequency 7Hz
- Thermal sensitivity <347mK
- Automatic acquisition of hot and cold spots
- Camera for acquisition of images in BMP format (max. 100 images)
- Adjustable emissivity
- Power supply: 3 alkaline AAA batteries
- USB interface
- IP54
- Temperature range: -20 °C ÷ +600 °C
- Infrared band: 6.5÷14µm
- Visible/infrared image fusion: 0.5; 1; 2m
- Alarm function, selecting acceptable maximum and minimum temperatures

~~£ 873.00~~  
£ 489.00



## 9710

### LUBRIBETA

7-in-1 multipurpose unlocking lubricant

1. Unlocking;
  2. Lubricating;
  3. Detergent, degreasing;
  4. Rust protective;
  5. Deoxidizing, for electrical contacts;
  6. Waterproof;
  7. Antifreezing
- Silicone-free.

400 ml



		£
9710 (1)	097100040	<del>£ 9.30</del> £ 5.90
9710 (2)	097101040	

## 9740

### BRAKE CLEANER

Brake cleaner

Ideal for cleaning brake discs and pads, engines.  
Allows any grease and tar deposits to be removed, without leaving residue. Also suitable as a general degreaser for metal surfaces.  
Evaporates quickly. Does not damage plastics and rubber.

400 ml



		£
9740 (1)	097400050	<del>£ 6.65</del> £ 3.90
9740 (2)	097401050	

## 9841N

### BLACK SEAL

Black acetic-reticulation silicone sealant

- Withstands temperatures
- The convenient dispenser allows easy (one-coated), accurate, uniform spreading of the product

Ideal for oil sumps, oil pumps, housings, gearboxes, engine parts that are not subject to high pressure and applications that require resistance to high temperatures

~~£ 28.00~~  
£ 14.50

200 ml



WITHSTANDS TEMPERATURES UP TO 240°C

### CARB CLEANER

Cleaner for carburettors and throttle bodies

Specific for interior and exterior cleaning of carburettors, suction ducts and throttle bodies. Totally removes carbonaceous residue, deposits and impurities. Evaporates quickly. Free from oil residue.

400 ml



		£
9745 (1)	097450040	<del>£ 9.80</del> £ 6.50
9745 (2)	097451040	

## 9712

### ULTRA SBLOCK

Unlocking lubricant, super-penetrating

Unlocking, deoxidizing, highly penetrating, for quick rust and oxidation removal from nuts, bolts, screws and gears. Waterproof, for water and humidity removal from treated parts. Highly resistant to cold and heat (-40 °C ÷ +150 °C).

400 ml



		£
9712 (1)	097120040	<del>£ 6.80</del> £ 4.50
9712 (2)	097121040	

## 9746

### CLIMA CLEANER

Air conditioner cleaner

- Thick foam formulation
- Suitable for industrial, civil and car air conditioners
- Removes dirt, deposits and odours from ducts
- Leaves a pleasant fragrance
- Supplied with a straw

400 ml



		£
9746 (1)	097460040	<del>£ 12.20</del> £ 6.50
9746 (2)	097461040	

## 9742

### CONTACT CLEANER

Cleaner for electric and electronic contacts

Useful for cleaning and cleansing electronic contacts, circuits and electrical components in general. Its non-thick consistency allows uniform, quick distribution on treated surfaces, removing grease and dirt, without leaving oily residue. Evaporates quickly. Does not damage plastics and rubber.

400 ml



		£
9742 (1)	097420040	<del>£ 7.25</del> £ 4.90
9742 (2)	097421040	

## 9720

### MULTI GREASE

Multipurpose grease

- Particularly useful for lubricating chains, gears and moving metal parts as well as hinges, locks and pivots
- Resistant to friction and weather
- Highly resistant to high temperatures (up to 210 °C)
- Highly adhesive. Does not drip

400 ml



		£
9720 (1)	097200040	<del>£ 7.85</del> £ 4.90
9720 (2)	097201040	

**1838CLAMP**

018380310

**Rechargeable clamp spotlight with adjustable light beam and 4 light intensities**

£ 80.50  
**£ 47.50**

- 4 light intensities:
  - 1600 lm - Ultra high mode
  - 700 lm - High mode
  - 300 lm - Low mode
  - 100 lm - Eco mode
- Rechargeable battery: Li-Ion 3.7 V, 5200 mAh
- Can be charged with USB-C cable (included)
- Can be rotated 360°
- Charging time: 4h
- Battery life:
  - 3h - Ultra high mode
  - 5h - High mode
  - 8.5h - Low mode
  - 24h - Eco mode
- 3-LED battery level indicator
- With built-in clamp, can be easily clamped everywhere
- 1 magnet on back
- IP65; IK07



**NEW**

**1838COMPACT**

018380011

**Rechargeable, compact LED lamp**

£ 63.00  
**£ 33.90**

- Dual light emission: main and spot
- 3 light intensities:
  - main COB LED 300 - 120 lumens
  - spot SMD LED 150 lumens
- Rechargeable battery: Li-Ion 3.7 V, 1500 mAh
- Charging time: 2.5h
- Battery life: main: 7/3.5h / spot: 6h
- Belt clip/pocket
- IP65; IK07
- USB-C cable included



**1838SLIM**

018380221

**Rechargeable, articulated slim 3-LED inspection lamp**

£ 74.00  
**£ 40.50**

- Triple light emission:
  - front: 100/200 lumens
  - back: 180 lumens
  - spot (head): 80 lumens
- Magnetic base
- Charging time: 2.5 h
- Battery life: 2-4 h / spot 3 h
- IP54; IK07
- L 307 mm



**1838AM**

018380400

**Rechargeable LED inspection lamp**

£ 109.00  
**£ 59.90**

- Double light emission:
  - front: LED COB, 60-700 lumens, can be adjusted with potentiometer
  - spot (head): LED SMD, 120 lumens, ON-OFF switch
- Rechargeable 3.6V 2600mAh Li-ion battery
- With USB-C port
- Supplied with 100-240V / 50-60Hz charger
- Charging time: 4h
- Battery life: front: 2.5-16h
- spot (head): 10h
- 3-LED battery level indicator
- Magnetic base (with neodymium magnet), can be rotated 90°
- Swivel base hook
- Articulated, can be rotated 180° (± 90° compared to axis)

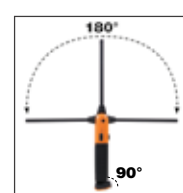

L 405 mm

**1838E**

018380270

**Rechargeable under bonnet LED lamp**

£ 187.00  
**£ 106.00**

- Triple light emission: 500/1000/2000 lumens
- Can be rotated 360°
- Length range: 116 ÷ 188 cm
- Aluminium body
- Nonslip rubber hooks
- USB-C charge
- Supplied with battery charger
  - Input: 100-240V ~ 50/60Hz
  - Output: DC 5V - 2000 mA
- IP 20
- IK 07



**2 charging modes:**  
charge via lamp USB port  
charge via internal battery USB port



**1838E-BT**

018380271

**Rechargeable battery with USB-C port for under bonnet lamp item 1838E**

£ 52.50  
**£ 30.00**

- Li-Ion 3,6V - DC 5V - 2000 mA

# KIT WIRELESS

## 1839W/P2

018390805

Kit of wireless lamps 1838SW, 1838POCKET, with compatible charging base 1839BRW

- Rechargeable, articulated LED inspection lamp 1838SW, wireless rechargeable
- Articulated pocket LED lamp 1838POCKET, adjustable, with dual light beam, wireless rechargeable
- Wireless charging base 1839BRW compatible with kit lamps



~~£ 260.00~~  
**£ 131.00**



**NEW**

## 1838SW

018380142

Rechargeable, articulated LED inspection lamp and wireless charging

- Dual light emission
- Base can be rotated 180°
- Nonslip rubber body
- Double swinging hook
- Magnets on base and back
- USB cable included

~~£ 98.00~~  
**£ 56.00**



## 1838/13LED-W

018380112

Rechargeable high-brightness LED lamp, wireless

- Dual light emission
- Supplied with USB-C cable
- Battery level indicator
- Swinging hook
- 1 magnet on base
- 2 side magnets

~~£ 141.00~~  
**£ 80.50**



**NEW**

## 1838FLASHPRO

018380301

Rechargeable, ultracompact spotlight, designed to provide the best solution for each use

- Rechargeable battery: Li-Ion, 3.6V, 10.000 mAh
- Can be charged via power supply with USB-C port
- Supplied with USB-C cable and power supply
- Battery level indicator
- Charging time: 7,45 h
- Battery life: 8.5 h
- IP65
- IK07

- 3 light intensities: LED SMD 1200 - 1000 - 800 lumens

~~£ 217.50~~  
**£ 122.00**



**NEW**



POWER TOOLS

1972/K12V-10

019720112

Ultracompact drill, 12V

- Double mechanical speed with steel gears and 20-position clutch
- Torque up to 30 Nm and 1300 rpm (400 rpm in 1st gear); drills diameters up to 10 mm in steel and 20 mm in wood
- 2Ah batteries and charge indicator on drill body
- Ergonomic nonslip handle
- Front LED
- 10-mm autochuck
- Belt clip (right/left side)
- Selector switch, screwing-unscrewing-locking modes (for transportation)
- Supplied in a hard case with 2 lithium ion batteries (2 Ah) and quick charger (50 min)

**Ultracompact:** no more than 170 mm in length;  
**Ultralightweight:** no more than 1.1 kg, with battery, and perfectly balanced



~~£ 261.00~~  
**£ 93.50**



1956 115-750W

019560011

Angle grinder for discs Ø 115 mm

- Powerful motor (750 W)
- Nonslip ergonomic handle for increased comfort and safety
- Lowered head that allows working in confined spaces
- Extremely lightweight (weighs no more than 1.8 kg)
- Protection against accidental activation
- Additional handle that can be mounted on both sides
- Tool-less disc cover (quick release)
- Spindle lock device for quick disc changes
- Lock-on/off slide switch
- Air vents protected against dust infiltration and providing optimal cooling performance
- Service wrench included



~~£ 81.00~~  
**£ 42.50**



- Free speed: 11,000 rpm
- Tool spindle thread: M14
- Tangle-free cable length: 4 m

1984/K600+BORSA

019840038

20V kit of reversible impact wrench 600 Nm + 4 Ah battery 1984/K600

~~£ 695.00~~  
**£ 309.00**

**1984/K600**  
Reversible impact wrench, brushless, 20V, 600Nm.  
Supplied in a hard case complete with 2 4 Ah batteries and quick charger.



1984/K1200+BORSA

019840039

20V kit of reversible impact wrench 1.200 NM + 6 Ah battery

~~£ 832.00~~  
**£ 425.00**

**1984/K1200**  
Reversible impact wrench, brushless, 20V, 1,200 Nm.  
Supplied in a hard case complete with 2 6 Ah batteries and quick charger.



Included in the price is a C9PT bag with a net value of **£ 27.50**



1/2" male square drive,  
3 different torque settings in screwing mode, 2 in unscrewing mode  
Digital BRUSHLESS motor for increased power, reduced energy consumption, extended motor service life, improved power supply from button.

**NEW**

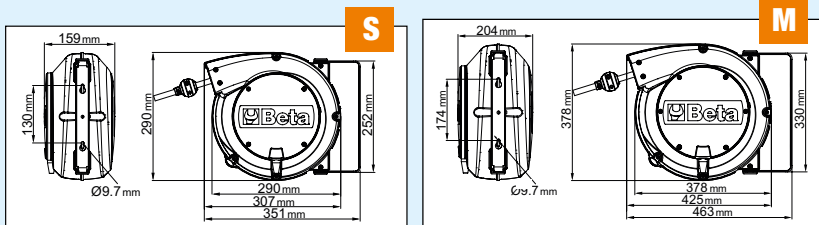

**Automatic hose reel**

- Automatic hose reel, shockproof plastic body, for air or water
- Max. operating pressure: 15 bar
- Braided polyurethane hose
- Polypropylene frame
- Device for automatically fixing hose at required length
- Rack mechanism can be disabled to keep hose pulled
- Water operating temperature range: -5 °C / +50 °C
- Supplied with a 180° swivel bracket and an additional quick connection bracket

		Hose	Ø GAS BSP	L m		£
<b>1900S 8X10</b>	<b>S</b>	Ø 8x12 mm	1/4"	10	019000080	<del>£ 173.00</del> <b>£ 75.90</b>
<b>1900M 8X15</b>	<b>M</b>	Ø 8x12 mm	1/4"	15	019000085	<del>£ 236.50</del> <b>£ 103.00</b>
<b>1900M 10X15</b>	<b>M</b>	Ø 10x14 mm	3/8"	15	019000115	<del>£ 247.00</del> <b>£ 113.00</b>
<b>1900M 12X15</b>	<b>M</b>	Ø 12x16 mm	1/2"	15	019000125	<del>£ 322.00</del> <b>£ 151.00</b>



**1844 15-H05**

**Automatic cable reel, with 3Gx1.5 mm<sup>2</sup> cable**

- 3Gx1.5 mm<sup>2</sup> cable
- With thermal protection switch
- Cable length out of drum: 1 m (except for 1844 30-H05, 2 m)
- Supplied without incoming cable
- Rack mechanism can be disabled to keep cable pulled
- Max. power (rolled up): 1500W (230V-20°C)
- Max. power (unrolled): 2500W (230V-20°C)
- Supplied with a 180° swivel bracket and an additional quick connection bracket



	Cable	L m	N° Schuko		£
<b>1844 15-H05/SCK</b>	H05VV-F	15	1	018440316	<del>£ 234.00</del> <b>£ 119.00</b>
<b>1844 15-H05/3SCK</b>	H05VV-F	15	3	018440319	<del>£ 232.00</del> <b>£ 122.00</b>

**> NEW <**

**1845EM/3**

018450403

**Automatic cable reel, with 3Gx2.5 mm<sup>2</sup> cable and TYPE 2 socket for charging electric vehicles**

- 3Gx2.5 mm<sup>2</sup> cable
- With thermal protection switch
- Cable length out of drum: 1 m
- Supplied with a 1.5-m-long incoming cable and a TYPE 2 socket
- Rack mechanism can be disabled to keep cable pulled
- Max. power: 3000W (230V-50Hz-16A)
- Supplied with a 180° swivel bracket and an additional quick connection bracket



~~£ 488.00~~  
**£ 275.00**



**> NEW <**

**1273MQ/D6** >> 012730851 <<

Set of 6 screwdrivers

1274MQ 3x100-4x100-5,5x125 mm  
1272MQ PH0x60-PH1x80-PH2x100 mm

1000 V EN 60900



£ 72.50  
**£ 42.00**

**1997MQ/GM** >> <<

Composite insulating gloves

EN 60903  
EN 61482

CLASSE 0

1000 V



	G		£
<b>1997MQ/GM 9</b>	9	019970109	<del>£ 169.00</del> <b>£ 93.50</b>
<b>1997MQ/GM 10</b>	10	019970110	<del>£ 169.00</del> <b>£ 93.50</b>

**1760PT/N** >> 017600155 <<

Voltage and continuity tester, 1000V

Voltage and continuity tester: accuracy and reliability with up to 1000V power. Equipped with a high-visibility digital screen and a convenient self-test function, the tool ensures both accuracy and reliability in each measurement, which makes it a must-have for every professional.



£ 117.00  
**£ 66.00**



Features:

- Voltage: 24÷1000VAC / 6÷1000VDC
- Bar voltage indicator: 6-12-24-50-120-230-400-690-1000
- Accuracy: ± (3% + 3)V
- Response time: < 1s (09%)
- Maximum absorbed current @1000V: < 3,5mA
- Contact-free voltage detection: > 90VAC
- Phase rotation test: 100÷1000VAC (50/60Hz)
- Phase angle: 120° ±5°
- Continuity test: 0±1.3 MΩ
- Current (continuity test): ≤5 µA
- Pollution level
- Power supply



**1760OHM/2** >> 017600027 <<

Megohmmeter for high voltage insulating testing

Our megohmmeter is synonymous with technology and accuracy for really professional measurements. With an insulating capacity up to 100 GΩ at 1000V voltage, this instrument is ideal for professional, accurate measurements in all electrical applications. **Particularly suitable for electric and hybrid cars.**



£ 380.00  
**£ 209.00**

Features:

- Insulation test up to 100 GΩ with 1000V voltage
- Large direct reading display, backlit
- Water protection: IP67
- Rubber terminal base for enhanced operating comfort
- Double insulated terminals CAT IV 600V, CAT III 1000V
- Ideal for electric and hybrid cars



	Measuring range	Basic accuracy
AC voltage:	10V - 600V	±(1.5% +5)
DC voltage:	0V - ±600V	±(1.5% +5)
Resistance:	0.01Ω - 200Ω	±(2% +5)
Insulation test @1000V:	0.01Ω - 100GΩ	±(1.5% +5)
Frequency:	1~1KHz	±(0.1% +3)

**2115PL-MQ32** >> 021150332 <<

Assortment of 32 insulated tools for hybrid cars, in plastic tool box with soft thermoformed tray

Quantity/Description

- 1 1/2" reversible ratchet
- 2 single ring wrenches 10-12 mm
- 1 magnetic bit holder, insulated 1/4"
- 10 set of 10 bits with magnetic bit holder  
T7-T8-T9-T10-T15-T20-T25-T27-T30-T40
- 7 hexagon sockets 8-10-12-13-14-17-19 mm
- 1 1/2" square drive extension bar 125mm
- 1 1/2" square drive extension bar 250mm
- 1 slip joint pliers, boxed joint 250mm
- 1 combination pliers 1000V = 180mm
- 1 extra-long bent flat nose pliers = 160mm
- 2 screwdrivers for cross head Phillips® screws, 1000V  
4.5X80-6X100 mm
- 3 screwdrivers for headless slotted screws, 1000V  
3X100-4X100-5.5X125
- 1 insulating gloves, made from latex G2
- 1 tool box, long series, made from plastic

- Beta N.
- 920MQ/55A
  - 89MQ
  - 850MQ
  - 861TX/A10
  - 920MQ/A
  - 920MQ/21
  - 920MQ/22
  - 1048MQ
  - 1150MQ
  - 1164MQ
  - 1272MQ
  - 1274MQ
  - 1997MQ/GM
  - CP15L



£ 1,275.00  
**£ 679.00**

1000 V

12"

## 5100 RSC51-MQ38

051000353

**Service tool trolley with 3 drawers and assortment of 38 repair and maintenance tools for hybrid and electric vehicles**

**RSC51-R**

- ABS reinforced worktop, solid and sturdy
- Multipurpose top with anti-fall edges and 8 holes for accommodating screwdrivers
- 3 drawers (588x367 mm) with ball bearing slides, 70 mm high
- Drawer bases protected by foamed rubber mats
- Each drawer can accommodate up to 4 EVA foam or ABS thermoformed trays
- Front centralized safety lock 400

- Convenient side screwdriver holder included
- Two built-in side spray can holders
- Large lower shelf protected by an anti-oil and anti-petrol rubber mat
- 4 castors, Ø 125 mm: 2 fixed castors and 2 swivel castors (one with brake)
- Capacity of each drawer: 15 kg, evenly distributed

**Quantity/Description**

- 7 single open end wrenches, 1000V 10-11-12-13-14-17-19 mm
- 3 single ring wrenches 10-12-13 mm
- 7 bi-hex sockets ○ 8-10-12-13-14-17-19 mm
- 1 3/8" drive, T-handle
- 1 3/8" drive reversible ratchet 203 mm
- 3 socket drivers for Torx® head screws ○ TX20-TX25-TX30
- 1 3/8" drive extension 140 mm
- 1 slip joint pliers, boxed joint 250 mm
- 1 diagonal cutting nippers 1000V  $\nabla$  160 mm
- 1 electrician's scissors 145 mm
- 1 combination pliers 1000V  $\equiv$  180 mm
- 1 extra long flat nose pliers  $\equiv$  160 mm
- 1 extra-long bent flat nose pliers  $\equiv$  160 mm
- 4 screwdrivers for cross head Phillips® screws, 1000V
- PH0-PH1-PH2-PH3
- 4 screwdrivers for headless slotted screws, 1000V
- 2,5x75-3x100-4x100-5,5x125 mm
- 1 cable stripping knife, insulated 190 mm

Beta N.	TR
52MQ	M159
89MQ	M159
910MQ/B	M159
910MQ/T	M159
910MQ/55	M159
910MQ/TX	M159
910MQ/21	M159
1048MQ	M161
1082MQ	M161
1128MQ	M161
1150MQ	M161
1162MQ	M161
1164MQ	M161
1272MQ	M161
1274MQ	M161
1777MQ/U	M161



£ 2,298.00  
**£ 949.00**



## 2400 RSC24/6-VEM

024004016

**Mobile roller cab with 6 drawers and assortment of 85 repair and maintenance tools for hybrid and electric vehicles**

**Quantity/Description**

- 1 insulating mat
- 4 plastic posts with fillable bases
- 1 multimeter/megohmmeter for high voltage insulation testing
- 1 combination voltage and continuity tester, 12-690V AC/DC
- 1 spare leads for digital multimeters and amperometric clamps
- 1 composite insulating gloves
- 1 pneumatic tester for insulated gloves
- 1 plastic barrier chain
- 2 aluminium warning signs
- 2 prohibition signs
- 12 single open end wrenches, 1000V 7-8-10-11-12-13-14-15-16-17-19-22 mm
- 12 single ring wrenches 7-8-10-11-12-13-14-15-16-17-19-22 mm
- 4 socket drivers for hexagon screws ○ 4-5-6-8 mm
- 11 bi-hex sockets ○ 7-8-10-11-12-13-14-15-16-17-19 mm
- 6 socket drivers for Torx® head screws ○ T15-T20-T25-T27-T30-T40
- 2 socket drivers with XZN® profile ○ 8-10 mm
- 1 3/8" drive extension 125 mm
- 1 3/8" drive extension 250 mm
- 1 3/8" drive, T-handle
- 1 3/8" drive reversible ratchet
- 1 electrician's scissors
- 1 slip joint pliers, boxed joint 250 mm
- 1 diagonal cutting nippers 1000V  $\nabla$  160 mm
- 1 combination pliers 1000V  $\equiv$  180 mm
- 1 extra long flat nose pliers  $\equiv$  160 mm
- 1 extra-long bent flat nose pliers  $\equiv$  160 mm
- 4 screwdrivers for cross head Phillips® screws, 1000V
- PH0x60 - PH1x80 - PH2x100 - PH3x150 mm
- 4 screwdrivers for headless slotted screws, 1000V
- 2,5x75 - 3x100 - 4x100 - 5,5x125 mm
- 1 cable stripping knife, insulated 190 mm

Beta N.	TR
1995MQ/T	
7104 90	
1760OHM/2	
1760PT/N	
1760DGT-R3	
1997MQ/GM	
1996VPG	
7105 6	
7109A	
7109D	
52MQ	M49
89MQ	M49
910MQ/PE	M108
910MQ/B	M108
910MQ/TX	M108
910MQ/XZN	M108
910MQ/21	M108
910MQ/22	M108
910MQ/T	M108
910MQ/55	M108
1048MQ	M161
1082MQ	M161
1128MQ	M161
1150MQ	M161
1162MQ	M161
1164MQ	M161
1272MQ	M161
1274MQ	M161
1777MQ/U	M161



£ 5,570.00  
**£ 2,605.00**

1000 V

**RSC24/6-R** 8



# BATTERY CHARGERS AND STARTERS



Following the acquisition of the established, reliable specialist manufacturer, Helvi, Beta Utensili has launched a new range of starters, battery chargers and testers, synonymous with **outstanding performance** and **quality standards**.

The range comprises **portable car** and truck starters, conventional and electronic **battery chargers** – including wheeled ones – and **battery testers**.

Beta relies on Helvi's manufacturing skills to provide an increasingly comprehensive and specialized range, with a view to answering the most demanding professionals' requirements.



## 1498PRO

### Portable starter, Pro

- **Graphic display with ammeter and charging status indication**
- Charging via automatic electronic power supplier
- Charging via cigarette lighter socket
- Internal protection fuse
- Shoulder strap included
- Sealed lead-acid storage battery (AGM)



## 1498PRO/12

☎ 014980812

## 1498PRO/12-24

☎ 014980824

### Portable starter, 12V, Pro

- For starting all GT and economy cars, 12V, petrol or diesel
- Pickup current: 3200A
- Battery capacity: 25 Ah

~~£ 738.00~~  
**£ 409.00**

### Portable starter, 12/24V, Pro

- For starting all vehicle types with 12V or 24V batteries
- Pickup current: 5000A 12V - 2500A 24V
- Battery capacity: 2 x 20 Ah

~~£ 1,325.00~~  
**£ 739.00**

## 1498EL

### Portable starter

- Charging via automatic electronic power supplier
- Charging via cigarette lighter socket
- Internal protection fuse
- Battery charging status LED indicator
- Shoulder strap included
- Sealed lead-acid storage battery (AGM)



## 1498EL/12

☎ 014980712

## 1498EL/12-24

☎ 014980724

### Portable starter, 12V

- For starting all GT and economy cars, 12V, petrol or diesel
- Pickup current: 1800A
- Battery capacity: 22 Ah

~~£ 483.00~~  
**£ 279.00**

### Portable starter, 12/24V

- For starting all cars and commercial vehicles with 12V/24V batteries
- Pickup current: 3600A 12V - 1800A 24V
- Battery capacity: 2x 22 Ah

~~£ 927.00~~  
**£ 539.00**

# 1498ULTRA

LITHIUM TECHNOLOGY

COMPACT, LIGHTWEIGHT AND POWERFUL, IT ALLOWS VEHICLES TO BE QUICKLY STARTED. THE LATEST-GENERATION MICROPROCESSOR PROVIDES FULL PROTECTION AGAINST:

- POLARITY REVERSAL
- SHORT CIRCUITS
- OVERLOADS
- OVERTEMPERATURE



## 1498ULTRA/12

014980960

### Portable lithium starter, 12 V

Compact, lightweight and powerful, it allows vehicles to be quickly started, e.g. under critical conditions, based on 5000A pickup current. Designed and developed by Beta, it comes complete with comprehensive electronic protection, backlit display, USB-C socket for power bank function and high-performance LiFePO4 battery.

~~£ 804.00~~  
**£ 469.00**

- Polarity reversal: 12 V
- Short circuits: 5000 A
- Overloads: 2500 A
- Overtemperature: 10000 mAh

## 1498ULTRA/12-24

014980970

### Portable lithium starter, 12-24 V

Compact, powerful and state-of-the-art, it is the ideal partner for the most demanding professionals: based on 10000 A peak power and 25 mm<sup>2</sup> cables, this starter provides high performance, which is also ideal for the flattest batteries and the toughest challenges.

~~£ 1,420.00~~  
**£ 789.00**

- Polarity reversal: 12-24 V
- Short circuits: 10000 A (12V) /5000 A (24 V)
- Overloads: 5000 A (12V) /2500 A (24 V)
- Overtemperature: 2 x 10000 mAh



## 1498BC/12

014980040

### Multipurpose portable starter, 12V

Device protecting against polarity reversal, short-circuit, overcurrent, overcharge and overheating

#### Supplied with:

- Protective case
- Cable with starting clamps
- USB ports for charging electronic devices
- LED battery charge indicator
- USB and USB-C cable
- Mains power supply
- Multifunction LED torch



Starting current	600A
Pickup current	1500A
Battery type	4 cells, LifePo4
Battery capacity	25000mAh

# 1498H

## Electronic multipurpose battery charger

Electronic battery chargers 1498H: innovation and technology made to work for professionals! Fitted with LCD displays and 3-colour LED indicators, they can be used with all types of batteries, both lead-acid and lithium. The electronic control card provides full protection against unexpected events. The 9 automatic charging steps ensure fast, efficient charging, with recovery and desulphation features.



IP65



- LCD display
- 3-light intensity LED
- Charging and charge maintenance
- Protection against reverse polarity, short-circuits, overheating, overloading, overtemperature
- Spark protection
- 9 charging steps
- Floating system
- Functions: battery recovery, battery test and desulphation
- Clamp holder
- Reclining fixing hook
- Supplied accessories: cable with clamps, cable with eyelets



		£
<b>1498H/4A</b>	014980204	<del>£ 156.00</del> <b>£ 87.00</b>
<b>1498H/8A</b>	014980208	<del>£ 192.00</del> <b>£ 106.00</b>
<b>1498H/16A</b>	014980216	<del>£ 283.00</del> <b>£ 160.00</b>
<b>1498H/25A</b>	014980225	<del>£ 302.00</del> <b>£ 169.00</b>

	<b>1498H/4A</b>	<b>1498H/8A</b>	<b>1498H/16A</b>	<b>1498H/25A</b>
<b>Power supply (1ph)</b>	230 V - 50/60 Hz	230 V - 50/60 Hz	230 V - 50/60 Hz	230 V - 50/60 Hz
<b>Charging current</b>	1-4 A	2-8 A	4-16 A	6-24 A
<b>Battery types</b>	Pb - GEL - Ca/Ca - AGM - Start/Stop - Lithium (LiFePo4)			
<b>Charging capacity</b>	5-80Ah (LiFePO4 1-80Ah)	10-160Ah (LiFePO4 2-160Ah)	20-360Ah (LiFePO4 4-360Ah)	30-550Ah (LiFePO4 6-550Ah)
<b>Maintenance capacity</b>	5-120Ah (LiFePO4 1-120Ah)	10-250Ah (LiFePO4 2-250Ah)	20-550Ah (LiFePO4 4-550Ah)	30-800Ah (LiFePO4 6-800Ah)
<b>Power supply (DC)</b>	N/A	13.8V - 5A	13.8V - 12A	13.8V - 20A
<b>Output voltage</b>	6-12V	12-24V	12-24V	12-24V
<b>Degree of protection</b>	IP65		IP20	

# 1498/AT

## Battery charger / starter, 12/24 V, wheeled

- For lead-acid storage batteries
- Charging current selector
- Ammeter
- Thermostatic long start protector
- Short-circuit protection fuse
- Reverse polarity protector



		£
<b>1498/AT701</b>	014980762	<del>£ 942.00</del> <b>£ 539.00</b>
<b>1498/AT1001</b>	014980763	<del>£ 1,550.00</del> <b>£ 885.00</b>
<b>1498/AT1300</b>	014980764	<del>£ 2,650.00</del> <b>£ 1,509.00</b>
<b>1498/AT2000</b>	014980765	<del>£ 3,750.00</del> <b>£ 2,129.00</b>

	<b>1498/AT701</b>	<b>1498/AT1001</b>	<b>1498/AT1300</b>	<b>1498/AT2000</b>
<b>Power supply</b>	(1ph) 230 V - 50/60 Hz	(3ph) 230/400 V - 50/60 Hz	(3ph) 230/400 V - 50/60 Hz	(3ph) 230/400 V - 50/60 Hz
<b>Power</b>	1800 W	2200 W	2900 W	3600 W
<b>Voltage</b>	12/24 V	12/24 V	12/24 V	12/24 V
<b>Maximum current</b>	75 A	90 A	120 A	150 A
<b>Charging current</b>	50 A	60 A	80 A	120 A
<b>Max. boost current</b>	550 Acc	980 Acc	1280 Acc	2000 Acc
<b>Starting current</b>	400 A	560 A	850 A	1100 A
<b>Charging capacity</b>	600 Ah 15h	1350 Ah 15h	1800 Ah 15h	2250 Ah 15h
<b>Charging positions</b>	6 + boost	14 + boost	12 + boost	12 + boost



**1498/DG**

**Electronic battery charger / starter, 12/24 V, wheeled**

Equipped with CPS (car protection system) technology, which allows boost function to be activated and deactivated fully automatically, to protect electronics on board vehicle.

- For Lead-Acid, AGM, Gel, Ca/Ca and Start/Stop batteries
- Electronic charge control via microprocessor
- Charging time setting
- Digital display
- Charging status LED indicators
- Control system for: reverse polarity, overcurrent, battery failure indication, safe start, protected start

**1498/DG540E**

014980770

**Battery charger / starter, 12/24V**

~~£ 930.00~~  
**£ 529.00**

**1498/DG1100E**

014980771

**Battery charger / starter, 12/24V**

~~£ 1,235.00~~  
**£ 709.00**

	<b>1498/DG540E</b>	<b>1498/DG1100E</b>
Power supply (1ph)	230 V - 50/60 Hz	230 V - 50/60 Hz
Power	1320 W	2400 W
Voltage	12/24 V	12/24 V
Maximum current	55 A	100 A
Charging current	36 A	70 A
Max. boost current	380 Acc	580 Acc
Starting current	260 A	400 A
Charging capacity	810 Ah 15h	5000 Ah 15h
Charging positions	4 + boost	4 + boost + supply



**1498/AM30**

014980740

**Automatic conventional battery charger 12/24 V**

- For AGM, GEL, Lead-Acid and Start/Stop batteries
- Electronic control of charging current
- Charging status light indicators
- Charging current regulation via potentiometer
- Automatic charging function
- Maintenance function



~~£ 579.00~~  
**£ 329.00**

Power supply (1ph)	230 V - 50/60 Hz
Power	720 W
Voltage	12/24 V
Maximum current	30 A
Charging current	20 A
Charging capacity	300 Ah 15h
Charging positions	∞

**1498/SP**

**Conventional battery charger / starter**

- For lead-acid storage batteries
- Charging current selector
- Ammeter
- Thermostatic long start protector
- Short-circuit protection fuse
- Reverse polarity protector

**1498/SP150**

014980745

**Conventional battery charger, 12 V**

~~£ 270.00~~  
**£ 138.00**

**1498/SP250**

014980746

**Conventional battery charger, 12/24 V**

~~£ 310.00~~  
**£ 176.00**

	<b>1498/SP150</b>	<b>1498/SP250</b>
Power supply (1ph)	230 V - 50/60 Hz	230 V - 50/60 Hz
Power	190 W	650 W
Voltage	12 V	12/24 V
Maximum current	15 A	27 A
Charging current	11 A	18 A
Max. boost current	120 Acc	200 Acc
Starting current	85 A	135 A
Charging capacity	165 Ah 15h	270 Ah 15h
Charging positions	2 + boost	2 + boost



**1498/PR**

**Conventional battery charger**

- For lead-acid storage batteries
- Voltage/current selectors
- Ammeter
- Automatic thermal overload protector
- Reverse polarity protector



**1498/PR14**

014980730

**Conventional battery charger, 6/12 V**

~~£ 179.50~~  
**£ 93.50**

**1498/PR17**

014980731

**Conventional battery charger, 12/24 V**

~~£ 198.50~~  
**£ 103.00**

**1498/PR20**

014980732

**Conventional battery charger, 12/24 V**

~~£ 246.00~~  
**£ 132.00**

	<b>1498/PR14</b>	<b>1498/PR17</b>	<b>1498/PR20</b>
Power supply (1ph)	230 V - 50/60 Hz	230 V - 50/60 Hz	230 V - 50/60 Hz
Power	140 W	300 W	390 W
Voltage	6/12 V	12/24 V	12/24 V
Maximum current	11 A	12,5 A	16 A
Charging current	7,5 A	8,5 A	11 A
Charging capacity	112 Ah 15h	128 Ah 15h	165 Ah 15h
Charging positions	2	2	2

**1498TB/12-24N**

014980402

**Digital battery tester, 12-24V, with built-in printer**

- Allows the following to be tested: battery, alternator, starter and system
- Reverse polarity protector
- Fitted with software for connecting instrument to PC
- Backlit display
- Compact, shockproof frame
- 9 language software

**Technical data:**

- Applications: 12V and 24V batteries
- Operating range: 100-2000 CCA
- Reference standards: CCA,SAE,DIN,EN,IEC,JIS, MCA, GB, BCI, CA
- Supported batteries: PB, WET, GEL, AGM, AGM FLAT, EFB, SLI
- Voltmeter: 9V-30V
- Cable length: 1800 mm
- Included accessories: USB cable, 3 printer paper rolls



~~£ 368.00~~  
**£ 205.00**



**1497/C94**

014970300

**Assortment of 94 car testing connectors for use with main diagnostic tools**

**Assortment contents:**

- 2 t-taps
- 2 potentiometers
- 2 warning lights
- 2 SRS connectors
- 2 alligator clips
- 2 acicular probes
- 2 prods
- 2 dual banana connectors
- 4 single banana connectors
- 24 flat male terminals 0.6÷6 mm
- 12 round male terminals 1.6÷3.9 mm
- 24 flat female terminals 0.6÷6 mm
- 12 round female terminals 1.6÷3.9 mm



~~£ 418.00~~  
**£ 229.00**

430x390x100 mm

**1497/C23**

014970200

Assortment of 23 tools for releasing electrical connectors

~~£ 233.00~~  
**£ 135.00**



440x250x70 mm

**1760DGT/2**

017600008

Digital automotive multimeter, portable, with 2-channel oscilloscope and waveform generator

~~£ 775.00~~  
**£ 425.00**



**Kit Contents:**

- Multimeter tips
- 2 BNC crocodile clips for oscilloscope
- Tip probe for oscilloscope (1X and 10X)
- Battery charger
- Nylon sheath



199 mm  
40 mm  
98 mm

**Oscilloscope Specifications:**

- Horizontal**
- Bandwidth: 40MHz
  - Sampling frequency range: 250MSa/s (single channel) - 125MSa/s (double channel)
  - SEC/DIV range: 5ns/div ÷ 500s/div 1,2,5 sequence

**Vertical**

- VOLTS/DIV range: 10mV/div ÷ 10V/div at BNC input
- Selectable analogue, bandwidth limit, typical: 20MHz
- Low frequency response (-3db): ≤10Hz a BNC
- DC Gain Accuracy: ± 3% for Normal or Medium acquisition mode, 10V/div ÷ 10 mV/div

**Trigger**

- Type: Edge
- Mode: Auto, Normal, Single
- Slope: Rising, Falling, Rising, & Falling
- Source: CH1, CH2

**Input**

- Coupling: DC, AC or GND
- Supported probe attenuation factors: 1X, 10X, 100X, 1000X

**Arbitrary waveform generator**

- Waveform frequency: Sine (1Hz ÷ 25MHz), Square (1Hz ÷ 10MHz), Ramp (1Hz ÷ 1MHz), EXP (1Hz ÷ 5MHz)
- Width: 2.5Vpp (50Ω) - 5Vpp (high impedance)
- Output impedance: 50Ω

<b>Max. voltage</b>	600V DC
<b>Max. current</b>	10A DC
<b>Max. resistance</b>	40MOHM
<b>Max. capacity</b>	100uF
<b>Display</b>	2.8" colour TFT
<b>Resolution</b>	320 x 240 pixels
<b>Power supply</b>	100V-240V AC, 50Hz-60Hz; DC INPUT 5V DC-2A
<b>Battery</b>	2 x 2600 mAh

**1760DGT**

017600005

Digital automotive multimeter

~~£ 278.00~~  
**£ 136.00**

**Technical Data:**

- RPM (tachometer):  
For 2 and 4 cylinder engines  
RPM4 600 - 4000 RPM  
RPM4 600 - 12000 RPM (x10 RPM)  
RPM2/DIS 300 - 4000 RPM  
RPM2/DIS 300 - 6000 RPM (x10 RPM)
- Dwell angle: 4-8 CYL
- DC voltage: 400mV-4/40/400/1000V
- AC voltage: 4/40/400/700V
- DC current: 40/400mA-4/20A
- AC current: 40/400mA-4/20A
- Resistance: 400Ω-4/40/400kΩ-4/40MΩ
- Capacity: 40/400nF-4/40/100μF
- Frequency: 5/50/500Hz-50/500-10MHz
- Duty cycle: 0.1 % - 99.9%
- Pulse amplitude: 1 - 10ms
- Diode test: Test current 0.3mA
- Continuity: <150Ω - Test current <0.3mA
- Display: High-contrast, backlit 4-digit LCD
- Overvoltage: Category II 1000V
- Auto power off: 30 minutes
- Power supply: 1 9V battery (included)
- Inductive clamp (included)
- 2 tips (included)
- Soft cloth case (included)



**1760B**

017600012

Digital multimeter

~~£ 179.50~~  
**£ 93.50**

**SPECIFICATIONS**

- DC voltage: 200 mV-2/20/200/1000
- VAC voltage: 2-20/200/700VDC
- Current: 2/20/200 mA-20 AAC
- Current: 2/200 mA- 20 A
- Resistance: 200Ω - 2/20/200 kΩ - 2/20 MΩ
- Capacity: 2/20/200 nF - 2/200 μF
- Temperature: -20° + 1000°C/ -4 °F ~ +2000°F
- Frequency: 20kHz
- Power supply: 1 9V battery (included)



1760PA/80

01760002

AC/DC amperometric clamp, 80A

Specifically designed to measure low current leakage or absorption values on vehicles

IDEAL FOR LOW LEAKAGE VALUES 1mA-80A

~~£ 238.50~~  
£ 132.00

SPECIFICATIONS:

- Range: 1mA-80A AC/DC
- Torch function with white LED
- Backlit LCD display
- Zero setting function
- Hold function
- Auto power off
- Power supply: 2 1.5V AAA-type batteries



1760PA/AC-DC

01760000

Amperometric clamp and digital multimeter

~~£ 343.00~~  
£ 194.00

Measurable parameters:

- DC voltage: 0.1mV ÷ 600V
- AC voltage: 0.1mV ÷ 600V
- AC current: 0.01A ÷ 1000A
- DC current: 0.01A ÷ 1000A
- Resistance: 0.1Ω ÷ 40MΩ
- Capacity: 0.001nF ÷ 40 μF
- Frequency: 0.001kHz ÷ 4kHz
- Temperature: -40°C ÷ 1000 °C  
-40°F ÷ 1832°F



1000A



1760PA/AC-DC2000

01760003

Amperometric clamp with digital multimeter and data connection

~~£ 677.00~~  
£ 279.00

Measurable parameters:

- DC voltage: 0.1mV ÷ 1000V
- AC voltage: 0.1mV ÷ 1000V
- AC current: 0.01A ÷ 2000A
- DC current: 0.01A ÷ 2000A
- Resistance: 0.1Ω ÷ 60MΩ
- Capacity: 1nF ÷ 6000 μF
- Frequency: 10kHz ÷ 20kHz
- Temperature: -20 °C ÷ 1000 °C  
-4 °F ÷ 1832 °F
- Power supply: 3 1.5V batteries, type AA (included)
- Data connection (version 4.0)



2000A



240x210x50 mm

1760/TC2

017600161

Combination contact/non-contact digital tachometer

~~£ 239.00~~  
£ 126.00

Supplied with the following:

- Adaptor for contact tip measurement
- Male (contact) rubber tip (2 pcs.)
- Female (contact) rubber tip (1 pcs.)
- Linear measurement tape (1 pcs.)
- Reflecting tapes
- Instruction manual

TECHNICAL DATA

- For measuring:
  - non-contact rotational speed (rpm)
  - contact rotational (rpm) and linear surface speed (m/min or ft/min).
- 5-digit LCD display.
- Scale:
  - non-contact speed 2.5÷99,999 rpm
  - contact speed 0.5÷19,999 rpm
  - linear surface speed 0.05÷1,999.9 m/min.
- Frequency: 0.8 sec.
- Power supply: 4 1.5V batteries (included), AA size, or 6V power supply unit (not included).



1760/IR500

017600350

Digital infrared thermometer with dual laser aiming system

~~£ 165.00~~  
£ 93.00



TECHNICAL DATA

- Temperature range: -50 ÷ 500 °C (-22 ÷ +932 °F)
- Display resolution: 0.1 °C (0,1 °F)
- Emissivity: 0.1 ÷ 1 adjustable
- Accuracy: -50 °C ÷ +20 °C (+/- 3 °C);  
20 ÷ 500 °C (+/-2% or 2 °C)
- Optical resolution (D:S): 12:1
- Auto power off: around 10 seconds
- Operating temperature: 0 °C ÷ 50 °C
- Storage temperature: -20 °C ÷ 60 °C
- Power supply: 1 9V battery



# 961N

009610030

## Electronic videoscope with flexible, rotating probe

- TFT LCD 5" screen
- Supports SD cards
- Video and image recording
- 4 LEDs
- Power supply via USB port (built-in battery)
- Rotating probe
- High resolution (1920x1080) for bright images and video
- Probe length: 1500 mm
- Camera diameter: 6 mm

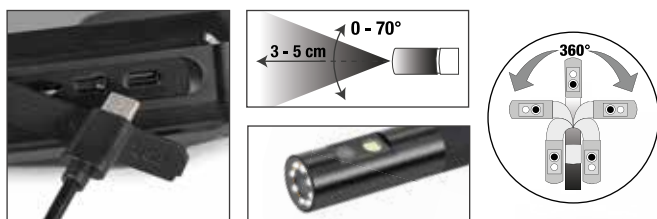

**Discover the videoscope, 961N, your versatile partner for all jobs!**  
 Based on the probe that can be rotated 360° and the double lit camera reaching the most inaccessible points has never been so easy. Defects and problems can be found easily and accurately. And with the new TFT LCD 5" display and outstanding resolution (1920x1080), you can enjoy sharp, bright images and videos, like never before. **Choose the videoscope, 961N, for uncompromised quality.**

~~£ 467.00~~  
**£ 269.00**



## Multi-purpose trolley

**Can be used as a mobile workstation for diagnostic tools, laptops, testers and battery chargers.**

- Painted sheet metal frame: unparalleled firmness and sturdiness
- Ergonomic handle
- 2 fixed rear castors Ø 160 mm
- 2 steering front castors Ø 100 mm (one with brake)

2 central shelves with adjustable position and 1 fixed low shelf



1099 mm  
 460 mm  
 435 mm



2-level top



Pull-out drawer for housing a mini keyboard



1 paper holder



2 useful side containers



4 useful side cable reels made of plastic

## CA49-G

049000112

**Multi-purpose trolley with door, empty**

~~£ 898.00~~  
**£ 469.00**

42 kg

## CX49-G

049000102

**Multi-purpose trolley, empty**

~~£ 898.00~~  
**£ 425.00**

40 kg

## 1464CBD/N

014640301

**Comprehensive adapter set for testing compression in petrol and diesel engines, with tester 1464T and 1464T/N**

~~£ 722.00~~  
**£ 425.00**

Makes it possible to connect to engine to test petrol and diesel compression with tester 1464T and 1464T/N

**Contents:**

- 8 dummy spark plugs with non-return valves
- 44 dummy glow plugs with non-return valves
- 1 adjustable universal dummy injector for cars, trucks, marine engines and agricultural machines
- 1 90° adapter, pressure release valve and connecting hose
- Space accommodating tester 1464T in case



510x410x140 mm

**NEW**

## 1464APD

014640100

**Set for testing high pressure system in common rail diesel engines, for use with item 1464T and 1464T/N**

~~£ 926.00~~  
**£ 540.00**

Allows connection between high pressure pump and injector flute, to test common rail system pressure.

**Set contents:**

- high pressure hose set:
- fittings
- 2,000 bar sensor
- assortment of dummy regulators
- assortment of injector fuel fitting plugs

**Supplied hose sizes:**

- T12X12-M1,5
- T12x14-M1,5
- T12x16-M1,5
- T12-M1,5

Bosch, Delphi, Denso and Siemens pressure regulators

510x415x130 mm



1464T/N ✓

## 1464T/N

014640090

**Digital pressure and compression tester**

~~£ 994.00~~  
**£ 575.00**

- Large digital display, backlit
- Rechargeable polymer lithium battery
- Complete with 80 bar sensor (for low pressure)
- Connection via cable free sensor
- Measurement and software update download via Wi-Fi
- Shockproof case
- For use in combination with kits 1464 for testing engine pressure and compression

**Beta's digital tester, 1464T, can be used to measure numerous parameters in the automotive industry.** The 80 bar pressure sensor it is fitted with can be used to test pressure and compression in petrol and diesel engines as well as oil pressure, the low pressure common rail circuit, and perform several other tests.

The internal software can be updated via Wi-Fi connection. The result of the measurements is displayed on the 8" touch screen. Data will be represented graphically or numerically, depending on the test that is being performed.



## 1464BP

014640200

**Set of connectors for testing low pressure, for use with item 1464T and 1464T/N**

~~£ 488.00~~  
**£ 279.00**

Provide optimal measurements with the set of low pressure adapters: efficiency and lasting performance for your engine. The quick connectors connected to tester 1464T/N make it possible to rapidly test fuel low pressure in diesel and petrol engines as well as AdBlue® and TDI pressure.



1464T/N ✓

510x415x130 mm

**Technical data:**

- Display: 8"
- Resolution: 800x840 px
- Processor: Dual core 240 MHz
- Internal memory: 32 Mb
- Software: 32-bits



### 1464PO

014640270

**Set for testing oil pressure, for use with item 1464T and 1464T/N**

~~£ 214.00~~  
**£ 130.00**

**Set contents:**

- 10 engine oil pressure fittings:
  - 1/8 DIN 2999
  - 1/8 x27 NPT
  - 1/4 x 18 NPT
  - 3/8 x 20 UNF
  - 1/2 x 20 UNF
  - M10 x 1.0
  - M12 x 1.5
  - M14 x 1.5
  - M16 x 1.5
  - M18 x 1.5
- 4 turbo oil pressure fittings:
  - M10 x 1.07/16 x 24 UNF
  - M12 x 1.5M14 x 1.5
- 90° fitting
- Rubber extension with quick coupling



350x290x90 mm

### 1464APB

014640500

**Set for testing high pressure system in FSI petrol engines, for use with item 1464T and 1464T/N**

~~£ 404.00~~  
**£ 188.00**

Comes with 200 bar sensor and connectors.



240x210x50 mm

### 1464FAP

014640610

**Set for testing diesel particulate filter (DPF) pressure, for use with item 1464T and 1464T/N**

~~£ 208.50~~  
**£ 102.00**

**Supplied with:**

- 500 mbar sensor
- 8 mm adaptor with quick coupling and T fitting
- 3-m-long RJ45 cable

**Technical data:**

- Pressure test: 0÷500 mbar
- Resolution: 1 mbar



240x210x50 mm

### 1464PT

014640550

**Set for testing turbo pressure, for use with item 1464T and 1464T/N**

~~£ 176.50~~  
**£ 87.00**

Comes with sensor and connecting cable.

**Technical data:**

Pressure test: 0÷3 bar  
Resolution: 1 mba



240x210x50 mm

### 1464VD

014640570

**Vacuum testing set, for use with item 1464T and 1464T/N**

~~£ 208.50~~  
**£ 106.00**

For measuring and storing maximum vacuum value.

**Supplied with:**

- 800 mbar sensor
- 6 and 8 mm adaptors
- 3-m-long RJ45 cable

**Technical data:**

- Vacuum test: 0÷800 mbar
- Resolution: 1 mbar
- Maximum value storage



240x210x50 mm

**CB52-0** 052000201

**Gearbox/transmission trolley with liquid recovery system**

Inclined plane and drain holes allow liquids to be recovered in collection tank

**Fitted with:**

- 4 swivel castors, including 2 with brakes
- Tool drawer
- Pull-out liquid collection tank; capacity: 7 l
- 2 shelves

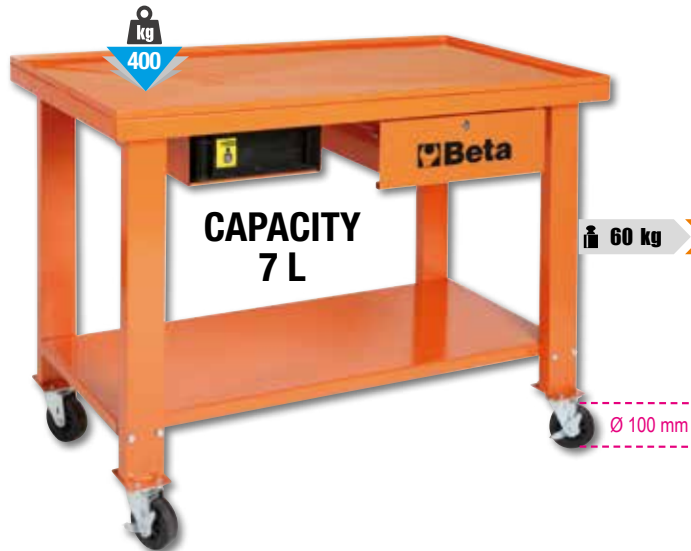
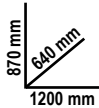

~~£ 771.00~~  
**£ 425.00**



**Exhausted oil drain unit**

- Level indicator
- Big diameter pan with breakwater grate; capacity: 12 l
- Pneumatic tank emptying through 1.8 m pipe
- Tool tray

**1877** 018770008

**Exhausted oil drain unit, wheeled, with 90 l tank**

~~£ 729.00~~  
**£ 425.00**



**1877A** 018770080

**Exhausted oil drain unit / vacuum cleaner, wheeled, with 90 l tank and pre-chamber**

~~£ 1,290.00~~  
**£ 739.00**

- Transparent pre-chamber: capacity 9.5 l
- Pneumatic tank emptying through 1.8 m pipe

**Standard accessories:**

- 1 hard probe, Ø 5x700 mm
- 1 flexible probe, Ø 5x700 mm
- 1 hard probe, Ø 6x600 mm
- 1 flexible probe, Ø 6x700 mm
- 1 flexible probe, Ø 7x700 mm
- 1 flexible probe, Ø 8x700 mm
- Adapters for VW, BMW, CITROËN



**1877P** 018770180

**Exhausted oil drain unit, wheeled, with polyethylene tank**

~~£ 565.00~~  
**£ 239.00**

- Tank capacity: 40 l
- Large oil pan made of PP
- Level indicator
- Pneumatic drum emptying



**1877F** 018770100

**Exhausted oil drain unit for 1 l bottles**

~~£ 99.50~~  
**£ 57.00**

- Fits up to 4 bottles at a time
- Supplied with 2 2-l jerrycans

**FITS UP TO 4 BOTTLES AT A TIME**

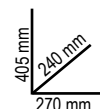

**1889N**

018890220

**Steel handling and storage base for 2 200-l barrels**

~~£ 832.00~~  
**£ 339.00**

- Easy to carry with a fork lift truck or a pallet jack
- Support cannot be placed under any part
- Completely hot painted with epoxy powder, for high resistance to chemicals



**TANK CAPACITY: 235 L**

**1756D**

017560515

**Suction gun, 1500 ml, made of polypropylene**

~~£ 81.00~~  
**£ 46.50**

- Double NBR gasket
- Operating temperature: +0 - +50 °C
- NOT suitable for fuel

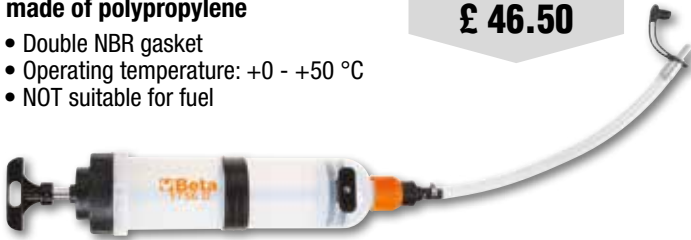

**1756G**

017560615

**Diesel oil gun capacity: 1.5 l**

~~£ 124.50~~  
**£ 70.90**

Can be used to:

- Fill diesel oil filters
- Fill Cerina tank

**Kit contents:**

- 2 pipes with female quick couplings for connecting diesel oil pipes
- 2 male quick couplings, made of metal
- 1 cone-shaped adapter for rubber pipes



**1758ADB-45°**

017580060

**Non-return funnel for AdBlue®, with 45° coupling**

~~£ 38.00~~  
**£ 22.50**



**1756E**

017560610

**Syphon syringe, compatible with petrol**

~~£ 42.00~~  
**£ 23.50**

Syringe capacity: 200 ml



**1756V**

017560504

**Oil suction gun, 200 ml, made from polypropylene**

~~£ 41.00~~  
**£ 23.50**

- For transferring oil and brake fluid
- Operating temperature: +0 °C ÷ +50 °C
- Not suitable for fuel and flammable liquids
- Usable minimum oil density: lower than SAE30



**1756B**

017560220

**Pen oiler**

~~£ 22.80~~  
**£ 12.90**



- With non-slip knurl
- Operating temperature: -10 °C - +60 °C
- Minimum density of SAE 10 oil

**1880**

018800001

**Manual oil barrel pump**

~~£ 59.50~~  
**£ 35.90**

- For oil
- Do not use with aqueous fluids, acid solvents, Diesel oil, petrol and the like
- Complete with barrel connection, telescopic tube and delivery spout
- For use with 60, 100 and 200 l barrels



1758B

017580030

Non-return funnel with quick couplings

Particularly suitable for VAG cars.

£ 37.50  
£ 22.50

NON-RETURN



14825N

014820110

Quick coupler swivel pliers for fuel pipes, with articulated jaws

£ 62.00  
£ 36.00



L mm  
260

1488

Oil-filter wrench with double chain



	Ø mm		£
1488	60÷110	014880001	<del>£ 95.50</del> £ 47.50
1488L	60÷160	014880050	<del>£ 104.50</del> £ 53.50

1490

Strap wrenches for oil filters

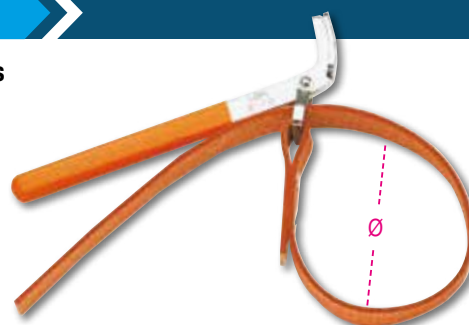

	Ø max mm		£
1490/1	160	014900001	<del>£ 38.00</del> £ 18.50
1490/2	240	014900002	<del>£ 41.00</del> £ 20.50

1488/1

014880010

Oil-filter wrench with thin double chain

1/2"

Ø mm  
60÷110

£ 110.50  
£ 47.50



1491

014910001

Adjustable oil filter wrench

£ 49.00  
£ 24.50

Ø mm  
65÷110



1493/C30

014930000

Set of 28 oil filter wrenches

- For tightening and loosening oil filters
- 1/2" female drive
- In plastic case

530x400x110 mm



£ 279.00  
£ 134.00

Sizes included in kit (Ø mm / n° sides) 1493:

65/14 - 68/14 - 73/14 - 74/15 - 76/15 - 75.77/15 - 76/14 - 76/8 - 78/15 - 80/15 - 82/15 - 86/16 - 90/15 - 92/10 - 93/15 - 95/15 - 100/15 - 106/15 - 108/15  
1493PF (Purflux)  
66/6 - 76/12 - 76/30 - 86/18  
93/36 - 93/45 - 96/18 - 108/18

Includes 1 adjustable oil filter wrench universal Ø 65÷120 mm

## 1899A/N-M

018990021

### DPF/FAP® system cleaning machine

#### Supplied with:

- 1 2-m-long feed pipe
- 1 quick coupler + hose nozzle for differential sensor hoses
- 1 niple M18x1.5 with hose nozzle for direct connection to lambda probe
- 1 extension hose
- 1 DPF/FAP® spray nozzle
- 1 magnetic pipe support
- 1 DPF/FAP® pipe with adjustment cable gland plus niple M14/16/18 mm for connecting lambda probes

#### Technical data:

- Operating voltage: 12 V
- Power supply cord length: 3.9 m
- Tank capacity: 1 l



£ 1,365.00  
£ 775.00



## 1852R1750/N

018520176

### Portable induction heater

- Heats and loosens bolts, hubs and bearings without using flames
- Allows any type of ferromagnetic metal to be heated.



5 kg



£ 1,525.00  
£ 849.00

480x370x130 mm

#### NEW COIL ADDED TO THE CASE



Two front attachable coils, Ø 19 and 26 mm, for loosening nuts



One flat coil for heating surfaces



One flexible coil, 800 mm long



One contact coil



#### BENEFITS

- 1 Time saving: quick, extremely accurate heating
- 2 Fire safety: does not produce flames, maximum operator safety
- 3 Functional: can be used with one hand, and coils can be easily interchanged

#### Fields of Application:

- Automotive industry
- Industrial maintenance
- Aviation industry
- Naval industry
- Petrochemical industry

#### Technical data:

- Input voltage: 230V AC, 50/60 Hz
- Input current: max. 7,5A
- Power: max. 1.75 kW



## 1852RL3700

018520370

### Portable induction heater, 3,7 kW, with coolant

The liquid-cooled portable induction heater is the ideal solution for the quick, efficient heating of ferromagnetic and conductive materials. The 2-m-long inductor results in remarkable versatility, catering to different work requirements.

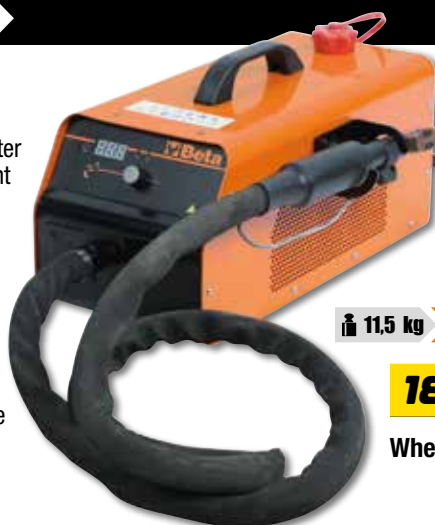

11,5 kg

£ 5,470.00  
£ 2,459.00



#### Technical data:

- Input voltage: U1 230 V 50/60 Hz
- Input current: I1 16 A
- Max. power: P2max 2400 W

#### Benefits

- Time-saving: quick, extremely accurate heating
- Fire safety: does not produce flames, maximum operator safety
- Functional: can be used with one hand, and coils can be easily interchanged.

## 1852RL-S/DR

018520551

### Wheel nut coils

£ 709.00  
£ 355.00



**960VTC** >> << 009600261

**Leakage tester for petrol engine cylinders**

After compressed air has been introduced into cylinder, gauge will allow it to be tested for compression leaks

Supplied couplers:  
**M10 - M12 - M14 - M14 long**

~~£ 287.00~~  
**£ 166.00**



2,3 kg

373x295x70,6 mm

**960KC-M8/M9/M10** >> << 009600801

**Assortment of tools for removing broken or damaged glow plugs**

~~£ 452.00~~  
**£ 255.00**

**FOR SPARK PLUGS WITH THREADS M8-M9-M10**



2,3 kg

380x290x50 mm

**960PI/K36** >> << 009600218

**Kit of brushes for cleaning injector seats**



~~£ 197.00~~  
**£ 114.00**

**Kit contents:**

- 12 nylon brushes, 8÷19 mm (1 mm interval)
- 12 steel brushes, 8÷19 mm (1 mm interval)
- 12 brass brushes, 8÷19 mm (1 mm interval)
- 1 bit holder with quick coupling and magnetic bottom
- 1 extension with quick coupling and magnetic bottom



1,2 kg

350x255x74 mm

**960KPC** >> << 009600780

**Reversible impulse extractor with adjustable torque for glow plugs**



~~£ 325.00~~  
**£ 188.00**

- Pneumatic extractor with adjustable torque and special sockets allow jammed glow plugs to be unscrewed, thereby minimizing damage risk
- 5 1/4" impact sockets, long series, specially designed for glow plugs: 8-9-10-11-12 mm, 2 extensions and 1 articulated joint
- 4 adjustable driving torques: 10-20-30-40 Nm
- Right-hand and left-hand adjustment



2,8 kg

420x185x60 mm

**1884** >> << 018840010

**Oil filler tool for manual and automatic gearboxes and differentials**

- Complete with 12 adaptors for direct connection
- Fitted with non-return valve for leakage-free oil filling
  - Delivery: 70 cc per pump shot
  - Tank capacity: 7.5 l
  - Maximum permissible oil viscosity: SAE 140



~~£ 500.00~~  
**£ 289.00**

**12 ADAPTORS**

FORD	AT-101
UNIVERSAL (Bmw, Honda, Nissan...)	AT-102
VW-AUDI	AT-103
VW-AUDI-PORSCHE	AT-104
VW-AUDI-MINI COOPER	AT-105
MERCEDES	AT-106
DSG	AT-107
VW-AUDI CVT	AT-108
VOLVO	AT-109
TOYOTA-LEXUS	AT-110
SKODA	AT-111
VW Passat/Tiguan <2007	AT-112



## 1759LR

017590070

### Cooling system washing tool

Based on the use of compressed air, high water pressure allows for effective cleaning system washing.

- Supplied with 6 system connection adapters
- Operating lever with position locking for continuous use
- Supplied with a water quick coupling

**REMARKABLE WATER POWER**

~~£ 455.00~~  
**£ 249.00**



390x330x100 mm



## 1759HD/3

017590063

### Cooling system seal testing and circuit filling tools

Make it possible to check circuit (pipes, joints, pumps, radiators) for leaks under pressure and quickly fill circuit, avoiding air bubble formation.

~~£ 593.00~~  
**£ 289.00**



6.5 kg

600x500x140 mm



## 1477/C38

014770338

### Kit with swivel ratcheting wrench, with short sockets for belt tighteners

~~£ 234.00~~  
**£ 135.00**

#### Kit contents:

- Swivel lever with 500-mm long reversible ratchet
- Short sockets for Torx® head screws: E10-E12-E14-E16-E18
- Short hexagon sockets: 8-9-10-11-12-13-14-15-16-17-18-19-24
- Bits for Torx® head screws: T20-T25-T27-T30-T40-T45-T50-T55-T60
- Bits for cross head Phillips® screws: PH2
- Hexagon bits: 4-5-6-7-8-10 mm
- Magnetic bit holder
- 3/8" extension, 75 mm

3/8"



630x130x55 mm

2 kg

## 1462/KI

014620235

### Assortment of common rail diesel injector pullers

Allows DELPHI-BOSCH-SIEMENS-DENSO injectors to be removed

~~£ 2,590.00~~  
**£ 1,309.00**

- Mechanical and hydraulic operation
- Includes one 12-t hydraulic jack
- Can be directly used on vehicle with mounted engine
- Numerous adjustment options on head make it possible to work on most engines available



2 kg

530x470x140 mm



## 1462/KEP

014620250

### Pneumatic diesel injector puller

~~£ 390.00~~  
**£ 229.00**

- Remote operation control
- Convenient positioning handle
- Threaded connection M18X1.5
- Slide hammer travel: 35 mm
- Slide hammer speed: 1200 bpm

4.8 kg



#### Connectors included in kit:

- M14X1.5 for Delphi
- M17X1.0 for Bosch
- M20X1.0 for Denso
- M25X1.0 for Siemens
- M27X1.0 for Siemens



385x300x110 mm

1895

**Ultrasonic cleaning tank**  
with special degas function

- Ultrasonic cleaning relies on fluid heating to effectively clean spare parts and metal pieces in general (carburetors, valves etc.)
- Digital display for temperature and cleaning time selection
- Two cleaning modes: "soft" and "normal"
- For normal cleaning, just use water at a temperature of 50/60 °C
- For more accurate cleaning, add non-foaming detergent solutions specific for ultrasonic tanks
- Using the degas mode speeds up air release throughout the tank, thereby improving ultrasonic cleaning efficiency

	1895 6	1895 13	1895 27	1895 157
Tank capacity	6 litres	13 litres	27 litres	157 litres
Drain tap	✓	✓	✓	✓
Power	150 Watt	300 Watt	500 Watt	2160 Watt
Heating power	300 Watt	400 Watt	500 Watt	5000 Watt
Temperature range	0+80 °C	0+80 °C	0+80 °C	30+110 °C
Cleaning time range	0-99 minutes	0-99 minutes	0-99 minutes	0-59 minutes
Frequency	40 kHz	40 kHz	40 kHz	28 kHz - 40 kHz
Power supply	220/230V	220/230V	220/230V	220/380V
Dimensions	330x180x310 mm	350x325x320 mm	530x330x380 mm	840x640x750 mm
Tank size	300x155x150 mm	325x235x145 mm	500x300x200 mm	700x500x450 mm



1895 6

018950060

Ultrasonic cleaning tank  
6 L

~~£ 740.00~~  
**£ 425.00**

1895 27

018950270

Ultrasonic cleaning tank  
27 L

~~£ 1,600.00~~  
**£ 919.00**

1895 13

018950130

Ultrasonic cleaning tank  
13 L

~~£ 1,148.00~~  
**£ 655.00**

1895 157

018950357

Ultrasonic cleaning tank  
157 L

~~£ 7,360.00~~  
**£ 3,905.00**



**ULTRASONIC CLEANER**

Industrial alkaline detergent  
for ultrasonic tank

9881U

098810010

~~£ 36.00~~  
**£ 20.00**

1 L



9881U 5

098810050

~~£ 142.00~~  
**£ 76.50**

5 L



1895GSI

018950810

Control generator for (petrol and LPG)  
electro-injectors

~~£ 146.00~~  
**£ 82.90**

Technical specifications:

- Power supply: 110V o 220V
- Test duration: 0~99 min.
- RPM: 600~4000

This tool relies on reduced dimensions and latest-generation software, to allow all electro-injectors to be activated, and functional, **accurate diagnoses and cleaning to be performed.**



**1898/K40**

018980004

**Eco friendly, heated manual cleaning tank**

- Using the bio-active liquid included, oil and residue can be effectively removed from mechanical parts without the need for aggressive chemicals
- The bio-active liquid converts the oil and other residue into carbon dioxide and water which can be re-used again and again
- No need for specialist waste collection and disposal
- Suitable for both metal and plastic parts

**Equipment:**

- Long bristle brush and connecting pipe
- Right-hand and left-hand operation function
- Perforated stainless steel grid
- Wheels with brakes
- Card with display operating temperature and low level alert

**Accessories Included:**

- 2 20 l cans of environmentally friendly liquid detergent and 2 packs of bacteria



~~£ 4,740.00~~  
**£ 2,365.00**



**ATTENTION:**  
Countries where product 1898/K40 is allowed to be distributed: Austria, Belgium, France, Hungary, Italy, Netherlands, Poland, Portugal, Spain, United Kingdom.

Max. pump capacity	10 l/min
Tank capacity	40 litres
Operating temperature	+5°C ÷ +40°C
Weight	50 kg (when empty)
Dimensions	710x370x200 mm



**1466/C5**

014660100

**Kit of 5 brake bleeding wrenches**

~~£ 133.50~~  
**£ 76.50**

**Kit contents:**

- 5 wrenches sizes 7-8-9-10-11 mm
- 1 drain hose with check valve



**OIL GOES INTO BUSH**

260x170x50 mm

**1471M/C22**

014710101

**Pneumatic tool for pushing back and rotating right and left disc brake pistons with accessories**

~~£ 318.00~~  
**£ 168.00**

- Automatic jack
- New assortment complete with all new adaptors
- Thrust: 150 kg
- Operating pressure 5-8 bar

350x310x85 mm



**1471C**

014710330

**Tool for manually pushing back brake pistons, with ratchet**

The tool for manually pushing back brake pistons, fitted with two swivel plates and a ratchet movement mechanism, means an effective, flexible solution for quick jobs - e.g. on commercial vehicles.

~~£ 64.50~~  
**£ 37.00**



1471PT/C5

014710367

Impact socket kit for brake calipers nuts

For cars of Volkswagen, Audi & Porsche group

- 3 10-tooth sockets: 11.5 mm - 15 mm - 20 mm
- 2 7-tooth socket: Ø 14 mm - 22 mm

12"

£ 76.00  
£ 43.50

Ø mm	L mm
25	50



7 teeth

10 teeth



1467LF/2

014670099

Electric instrument for brake fluid replacement

£ 1,855.00  
£ 995.00

Allows brake fluid to be easily and quickly replaced on vehicle

- Automatically stops when tank is empty, thereby preventing air from being let in
- Maximum tank volume: 20 l
- Operating pressure: 0.4÷3.5 bar
- Power supply: 230V

Supplied with:

- Brake oil recovery tank
- 1 standard cap E20



"PULSATING EFFECT"



15 kg



1467

014670001

Brake fluid extractor

£ 356.00  
£ 163.00

Pressure: min 5 bar, max 11.5 bar



1467T/C6

014670080

Set of adapter plugs for brake fluid tanks, for use with BETA items 1467LF and 1467LF/2

£ 283.00  
£ 163.00

Set contents:

- 1 plug for Toyota vehicles
- 1 plug for Ford, Hyundai, Mazda, Mitsubishi, Nissan, Subaru vehicles
- 1 plug for Honda vehicles
- 1 plug for Mazda and Suzuki vehicles
- 1 plug for Nissan vehicles
- 1 brake bleeding adapter plug for European vehicles



350x240x85 mm

**Tyre bead seater**

- Secondary handle with push-button operation helps keep hold of tool during use
- Pressure relief valve
- Gauge with graduated scale
- Plastic inlet preventing rim damage

**1950BZK**

019500078

Tyre bead seater

- **Tank capacity: 18 l**
- Operating pressure: 3-8 bar
- Maximum tank pressure: 16 bar

~~£ 324.00~~  
**£ 188.00**

Ø 290x440 mm



**1950BZK/T**

019500080

Truck tyre bead seater

- **Tyre bead seater for trucks, buses, agricultural vehicles and earth-moving machinery**
- **Tank capacity: 36 l**
- Operating pressure: 3-8 bar
- Maximum tank pressure: 16 bar

~~£ 404.00~~  
**£ 219.00**

Ø 290x560 mm



**Tyre inflator**

- Shockproof rubber coated body
- Metal operating lever
- Operating pressure: 0,5÷12 bar, 7÷174 psi
- Pipe length: 58 cm
- 360° hose rotation
- 1/4" air inlet

**1949GPA**

019490018



~~£ 112.00~~  
**£ 47.50**

- Pressure release feature
- Pressure measurement feature

**1949DGT/2**

019490021

**Digital tyre inflator**

- 4 units of measurement, bar/psi/kpa/kgf
- Backlit LCD display
- Resolution: 0.05 bar
- Self-power off after 1.5 minutes

~~£ 133.50~~  
**£ 56.90**



**1950GPP**

019500050

**Portable tyre inflator with automatic and manual charging, with inflating gun**

~~£ 273.00~~  
**£ 169.00**

**Technical data:**

- Tank capacity: 10 l
- Max. tank pressure: 16 bar (232 psi)
- Tank pressure gauge, Ø 50 mm: 0÷16 bar (232 psi)
- Operating pressure gauge: 0÷16 bar (232 psi)
- Inflating hose length: 1550 mm
- Empty weight: 9.3 kg



**NEW**

978-979

Four-way hexagon wheel nut wrenches

12" 

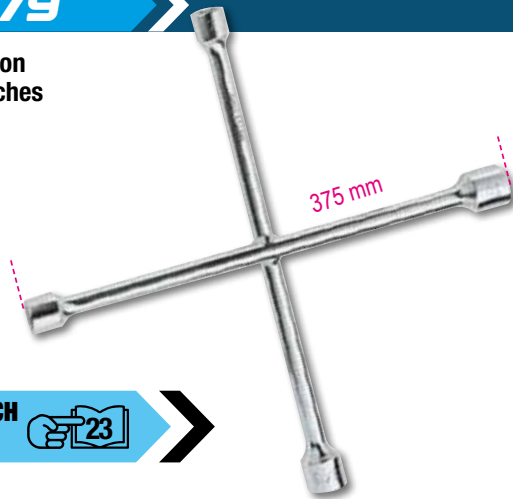

TORQUE WRENCH VERSION 

	mm		£
978	17x19x21x22 mm	009780001	<del>£ 67.00</del> £ 33.90
979	17x19x22x1/2 mm	009790001	<del>£ 67.00</del> £ 33.90

3035

030350100

Tyre trolley

- For easily transporting tyres up to 980 mm in diameter
- The sturdy frame allows tyres to be handled without bearing the weight physically
- Can be used as a top by locking position horizontally
- 2 castors Ø 260 mm
- 2 castors Ø 125 mm
- Maximum transportable height: 1.60 m
- Maximum carrying capacity: 200 kg
- Forks can be adjusted in 2 positions:
  - first position: maximum opening 880 mm
  - second position: maximum opening 980 mm

~~£ 1,004.00~~  
£ 539.00

30 kg 



962

Tyre levers



	L mm	A mm		£
962 500	500	27	009620005	<del>£ 38.00</del> £ 22.50
962 600	600	27	009620006	<del>£ 58.50</del> £ 28.50

972/C10

009720010

Removal kit for damaged wheel nuts

For use on anti-theft and conventional nuts

~~£ 303.00~~  
£ 171.00



290x250x60 mm



972/C4 BMW

009720004

Removal kit for anti-theft bolts with free rings, for BMW and Mini cars



~~£ 239.00~~  
£ 139.00



516x145x66 mm



### 720LC/C3

007200653

3 impact sockets for wheel nuts, with polymeric inserts

~~£ 39.00~~  
£ 22.90

17-19-21 mm



148x132x44 mm



### 720MRC

007200631

Impact socket with polymeric insert for Mercedes wheel screw

~~£ 20.80~~  
£ 12.90

Suitable for the following Mercedes models:

- Classe C e GLK (W204)
- Classe E (W211, W212, W207)
- Classe SLK (W172)
- Classe ML (W164, W166)
- Classe CL (W216)
- Classe S (W221, W222)

12"



mm	L mm
17	85



### 986 78

009860078

Tyre valve screwdriver

Automatic valve retention.

~~£ 15.40~~  
£ 9.00

L mm	L1 mm
78	18



### 720FRD

007200633

Impact socket for Ford wheel nuts with aluminium damaged caps

~~£ 19.80~~  
£ 12.90

Required when nut caps are damaged by impact wrenches



### 983PM

009830010

Abrasive brush for cleaning hubs



~~£ 78.50~~  
£ 46.00



Ø1 mm	Ø2 mm
90	150



mm	L mm
18,5÷19,5	63



### 720RNG

007200634

Impact socket for Jeep Renegade wheel nuts with aluminium damaged caps

~~£ 19.80~~  
£ 12.90

Required when nut caps are damaged by impact wrenches.



### 989

009890001

Wheel balancing weight tool

~~£ 50.50~~  
£ 28.50



L 250 mm

mm	L mm
16,5÷17,5	63



3008M

030080210

Manual jack and positioner for truck wheels

£127.00  
£ 73.50

This jack, which has a maximum carrying capacity of 136 kg, has been designed to make it easier to lift and handle large tyres. The frame with increased thickness and the reinforcements applied to the welding areas provide this device with remarkable sturdiness and firmness.

Features:

- Oscillation rollers for significantly improved wheel alignment with hub pins
- Dual wheels for easy tyre handling
- Ergonomic rubber-coated handle, for a firm, safe hold

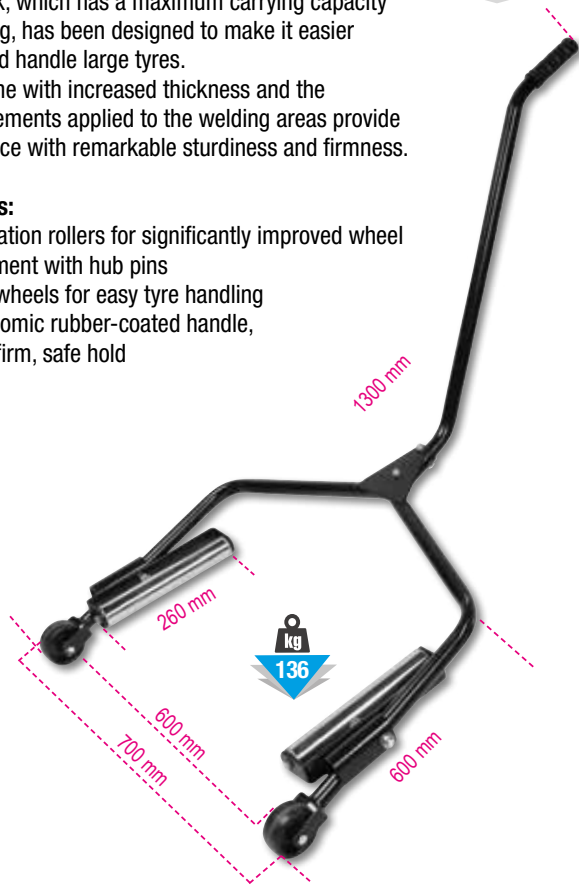

1567

015670001

Lever for removing wishbone heads and shock absorbers from pillar

£347.00  
£ 166.00

One operator can position lever effortlessly and proceed with disassembly

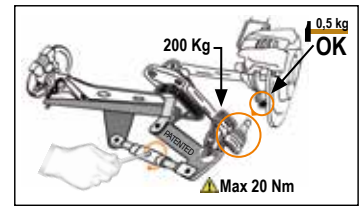
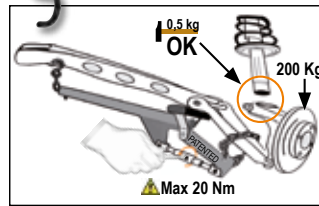

1568

015680001

Pneumatic assembly tool for silicone axle shaft boots

£247.50  
£ 144.00

- 8 spreader arms
- Maximum arm spreading: 145 mm



1566GO 1

015660052

Homokinetic joint puller

£151.00  
£ 81.50

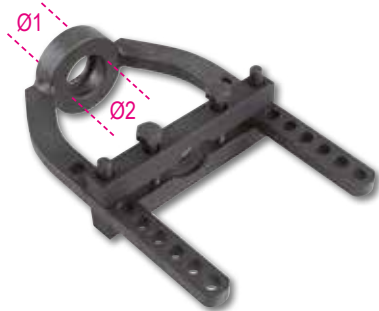

Ø1 mm	Ø2 mm
29	29

L mm	L1 mm
420	195

1530/C5

015300300

Wheel hub and bearing pulling kit, 3, 4, 5 holes

£568.00  
£ 309.00

Kit contents:

- 1 universal flange (96÷138 mm)
- 1 hydraulic screw (12 t)
- 1 hammer face (2.8 kg), required for hubs without central fixing bolts

15 kg



760x320x120 mm



## 1550U

015500010

**Pneumatic shock absorber removal tool for cars, SUVs and commercial vehicles**

~~£ 3,080.00~~  
**£ 1,705.00**

- Maximum thrust:  
2 tons (10 bars) - 1.6 tons (8 bars) - 1.2 tons (6 bars)
- Spring compression stroke: 335 mm
- Upper universal hold system that allows all left/right-hand spring diameters to be compressed with one upper adaptable plate
- Active safety system on spring: safety hook and 3 locking valves allow spring to be properly positioned/seated, maintaining such position throughout compression. If spring is not positioned properly, system will stop machine.
- Protective "Full Body" Grille: provides maximum safety and working area coverage
- Control Lever operation: increased accuracy and sensitivity during compression stage
- Working position: working height on rear fork raised up to 875 mm
- Supplied with 2 lower forks for diameters 78-205 mm



## 1552/C9

015520020

**Kit for spreading shock absorber, wishbone and steering wheel joints apart**

~~£ 129.00~~  
**£ 72.90**

Working with single or double retractor head also makes it possible to work on double joints, e.g. from VAG group.

195x140x40 mm



## 1556/1A

015560101

**Compressor for shock absorber springs**

~~£ 242.50~~  
**£ 125.00**

L Min÷Max= 65÷320 mm



## 1569/SB

015690016

**Assortment of tools for removing and installing rear axle silent blocks, driving shaft oil seals and wheel bearings**

~~£ 256.00~~  
**£ 138.00**

Bushings can be used both on vehicle and on hydraulic press

13 kg

425x365x100 mm



## 1768

017680010

**Aluminium footboard**

~~£ 196.50~~  
**£ 113.00**



**SURFACE COATED WITH NON-SLIP MATERIAL**

L mm	L1 mm	H mm
960	300	475



**1364SE**

013640001

**Extension bodywork support**

- 4 swivel castors, 2 with brakes
- Pantograph can be extended up to 1400 mm
- Vertically adjustable up to 1315 mm
- Position locking
- Contact surface covered with removable rubber



L mm	H mm	P mm
215÷1400	780÷1315	890

~~£ 416.00~~  
**£ 229.00**

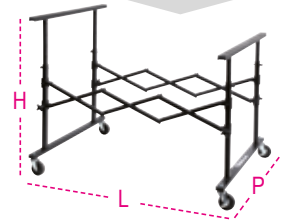

**1364SV**

013640002

**Bodywork support with central tray**

- Contact surface covered in polyethylene
- Tray dimensions: 340x845x40 mm
- Foldable



H mm
1000

~~£ 236.50~~  
**£ 134.00**



**1364SCP**

013640003

**Revolving bodywork support**

- Particularly suitable for bonnets, wings and doors
- Fitted with 4 castors - 2 steering with brakes
- Can be rotated up to 180°



**CAN BE ROTATED UP TO 180°**



L mm	H mm	P mm
1100	1300	680

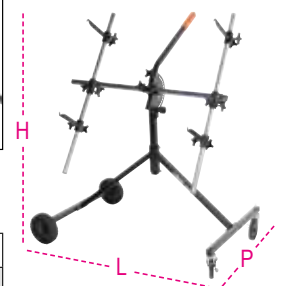

~~£ 379.00~~  
**£ 215.00**

**3009**

030090001

**Wheel lifter**

- Maximum lifting capacity: 550 kg
- 4 pivoting rollers
- Roller width: 200 mm
- For wheels up to 240 mm in width



**kg**  
**550**

~~£ 441.00~~  
**£ 249.00**

**IDEAL FOR:**

- LOADING DAMAGED CARS ONTO TOW TRUCKS
- CAR REPAIR GARAGES
- MOVING CARS IN SHOWROOMS

**1850D**

018500018

**3-speed heat gun**

**Functions:**

- Heat shrinking
- Stripping paint, softening PVC parts
- Soldering, welding
- Shrinking cables
- Thawing, drying, disinfecting
- Treating glued parts
- 4 nozzles included

- Pos. I 250 l/min 50 °C
- Pos. II 250 l/min 400 °C
- Pos. III 500 l/min 550 °C



**1800W**

~~£ 137.00~~  
**£ 70.90**



L mm	H mm	W	°C	V	l/min
255	210	1800	50-550	220/240	250/500

**1052**

018500018

**Adjustable self-locking pliers, concave jaws**

	L mm	ø Max mm	g		£
<b>1052/140</b>	140	22	175	010520014	<del>£ 27.50</del> <b>£ 15.90</b>
<b>1052/190</b>	190	36	360	010520019	<del>£ 31.00</del> <b>£ 17.50</b>
<b>1052/240</b>	240	42	590	010520024	<del>£ 33.00</del> <b>£ 19.50</b>
<b>1052/300</b>	300	55	900	010520030	<del>£ 55.00</del> <b>£ 31.90</b>

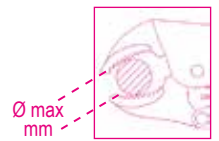

**1068**

010680000

**Adjustable self-locking pliers with hammer face**

The self-locking pliers with 1 kg sliding hammer face is ideal for pulling stud bolts, broken screws and sheets, especially in the car repair industry.



~~£ 124.00~~  
**£ 70.90**

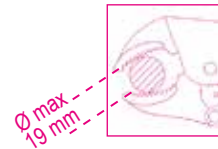

**1766**

017660001

**Double suction lifter**

~~£ 126.00~~  
**£ 66.00**



**1367/K10**

013670200

**Kit of punches for installing parking sensors**

~~£ 187.50~~  
**£ 107.00**

**Sizes Kit contents:**  
17 - 18 - 18,2 - 19 - 20 - 22,5 - 24 - 26 - 26,7 - 32 mm

190x130x58 mm

**PERPENDICULAR, BURR-FREE HOLES**



1479

014790001

Trim pin remover

~~£ 26.50~~  
£ 14.50



1478/K3

014780160

Pin removing pliers kit with plastic clips assortment

~~£ 108.00~~  
£ 62.50

Kit contents:

- flat nose pliers (1 pc.)
- 90° bent nose pliers (1 pc.)
- 625 plastic clips in 16 different sizes
- clips in 3 stackable PPL containers

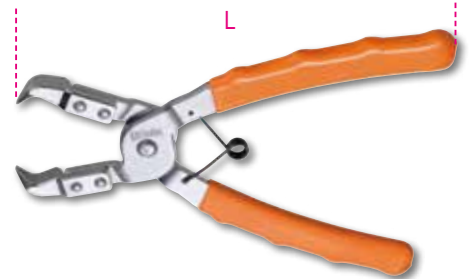

L mm	L1 mm
180	170

1479LB/C5

014790150

Kit of 5 metal trim pin removers

~~£ 112.00~~  
£ 64.50



215x165x50 mm

1365/K13

013650013

Oil pressure pump, 10 t, and bodywork accessories kit in handy trolley

Kit contents:

- Oil pressure pump, 10 t, with 1.5-m-long hose, 1/2" coupling
- Piston 205 mm
- Wing opening pliers; capacity: 500 kg
- Baseplate, 150x90 mm
- L-shaped base, 50x50 mm
- 4-point punch
- Round, knurled punch, Ø 50 mm
- Wedge-shaped punch, 43 mm
- 170-mm-long extension
- 300-mm-long extension
- 400-mm-long extension
- 530-mm-long extension
- Rubber head
- Male-to-male coupling for installing accessories



~~£ 820.00~~  
£ 469.00

33 kg

HANDY TROLLEY

900x420x180 mm

1361/K9

013610030

Kit of 8 levers for bodywork dent pullers

Kit contents:

- Round ball head rod, Ø 31 mm, length 110 cm
- Tip rod, length 62 cm
- Whale tail tip rod, length 112 cm
- Hook tip rod, length 27 cm
- Flat round head rod, length 50 cm
- Round ball head rod, Ø 19 mm, length 52 cm
- Whale tail head rod, length 27 cm
- Round whale tail head rod, length, 28 cm
- Fabric bag with handles

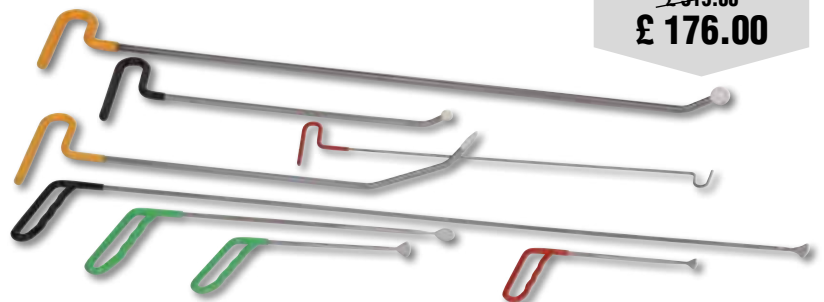

~~£ 315.00~~  
£ 176.00

## 1368N

01368002

### Plastic repair kit

- Power: 30 W
- Battery: 3.7 V 4000 mAh Li-ion
- USB type C power supply connector
- Maximum temperature: 600 °C
- Battery charger: input 230 V, output USB 5V - 2A
- Charging time: 3h at 2A
- Total overcurrent and overtemperature protection



~~£ 164.50~~  
**£ 84.50**

**ALLOWS CRACKED AND BROKEN PARTS TO BE QUICKLY FIXED**



**NEW**

## 1366SH

013660400

### Multifunction bodywork spotter

- Microprocessor for managing welding parameters
- Contact and manual welding cycle start
- Automatic spot welding time setting function
- Supplied with quick coupling gun and 2.2-m-long ground cable

#### Accessory kit contents:

- Extractor hammer
- Three-pointed washer head
- 10 three-pointed washers
- Carbon electrode
- Squashing electrode

Power supply	230V
50% power	2.5 KVA
Power peak	13 KVA
Amp output	2850 (2%) A
Max. Amp output	3200 A



23 kg

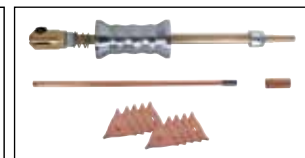

~~£ 2,070.00~~  
**£ 1,135.00**

## 2254K

022540101

### Reusable seat, steering wheel and gear knob protector

~~£ 30.00~~  
**£ 17.50**



## 2254F

022540150

### Car front protector

~~£ 90.00~~  
**£ 48.00**



## 1479/B27

014790407

### Kit of 27 nylon tools for removing pins and working on plastics and seals, hangable

~~£ 81.50~~  
**£ 43.50**



1870

018700020

Solid and fluid vacuum cleaner, 20 l

- Single-stage by-pass motor
- Voltage: 220/240 V
- Frequency: 50/60 Hz
- Max. power: 1200 W
- Airflow rate: 58 l/sec.
- Max. suction power: 190 mbar
- Max. drum capacity: 20 l, made of antistatic PP
- Acoustic emissions: <70 dB(A)
- Cable length: 5 m
- Trolley for accessories



FUNCTIONAL AND POWERFUL

IPX4

~~£ 244.00~~  
**£ 128.00**

- STANDARD ACCESSORIES Ø 36 mm:**
- 1 corrugated hose with ergonomic handle
    - 2 hard extension tubes
  - 1 multiuse brush for floors and fluids
    - 1 flat nozzle

**Filtering systems:**

- 1 surface filter cartridge 1900 cm<sup>2</sup> - 12 µm nom.
- 1 anti-foam filter PPI 45/PPI 30

1875LT

018750000

Injection/extraction carpet/upholstery cleaner

~~£ 587.00~~  
**£ 349.00**

**Ideal for deeply cleaning textile surfaces.**

It dispenses pressure sprayed detergent and sucks it up with dirt, leaving surfaces almost dry.

**Technical data:**

- Voltage: 230/240 V
- Frequency: 50/60 Hz
- Max. power: 1100 W
- Airflow rate: 58 l/sec.
- Max. drum capacity: 20 l
- Max. detergent tank capacity: 3 l
- Max. pump pressure: 7 bar
- Max. suction pressure: 21 kPa
- Pump power: 48 W
- 1 hose complete with ergonomic handle
- 1 dispenser unit
- 2 hard extensions
- 1 small spray extraction nozzle
- 1 big spray extraction nozzle
- 6 power cord locknuts

**HIGHLY EFFECTIVE FOR CAR SEATS AND INTERIORS**

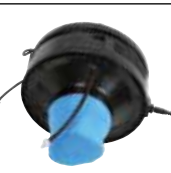

1874 50

018740050

Solid and fluid vacuum cleaner, 50 l, stainless steel drum

~~£ 898.00~~  
**£ 469.00**

- Two-stage by-pass motor
- Voltage: 220/240 V
- Frequency: 50/60 Hz
- Max. power: 1350 W
- Airflow rate: 55 l/sec.
- Max. suction power: 240 mbar
- Max. drum capacity: 50 l, made of stainless steel
- Acoustic emissions: <63 dB(A)
- Cable length: 6 m
- Trolley for accessories

**FILTERING SYSTEMS**

- 1 filter paper bag
- 1 surface filter cartridge 5200 cm<sup>2</sup>, 12 µm nom.
- 1 anti-foam filter PPI 45/PPI 30

**STANDARD ACCESSORIES, Ø 45 mm**

- 1 corrugated hose with ergonomic handle
- 2 stainless steel extension tubes
- 1 industrial brush frame
- 1 industrial section for carpets
- 1 industrial section with fluid collection hoses
- 1 flat nozzle



1898/S

018980932

Hand pressure pump with 5 l tank

~~£ 27.50~~  
**£ 17.00**

- Stainless steel nozzle
- Locking lever for continuous jet
- Adjustable nozzle with straight jet and mist spray
- Shoulder strap for ease of transport
- Nozzle hook-up handle
- 1.2-m-long hose
- Not for use with hydrocarbons



## CREEPER KIT

### 3003PRO/K

030030950

Creeper made from shockproof plastic material, wall-mounted plastic support

~~£ 441.00~~  
**£ 188.00**

#### 3003PRO

Creeper made of shockproof plastic

- Ergonomic head cushion
- Soft back protector
- 2 178 mm double bearing castors for trouble-free use on uneven surfaces and pipes/cables
- 1 swivel castor
- Double height adjustment from the ground: 38 or 76 mm
- 2 portable LED lamps (250 lumens) with fixing magnets

#### 3003PRO/SP

Wall-mounted plastic support for creeper 3003PRO



WALL-MOUNTED PLASTIC SUPPORT INCLUDED IN PRICE



7,7 kg

**NEW**

### 1898/M

018980930

Pressure sprayer with 1,5 l tank

~~£ 15.70~~  
**£ 9.50**

- Adjustable nozzle with straight jet and mist spray
- Graduated scale 0.5 l - 1 l - 1.5 l
- Locking lever for continuous jet
- Not for use with hydrocarbons



### 2250-O

022500011

Heavy duty swivel creeper seat with tray

~~£ 112.00~~  
**£ 65.50**

- Round swivel seat
- Height can be adjusted through a gas piston mechanism (410-530 mm)
- 2 tote/tool trays, one being vertically adjustable
- 5 pivoting castors



### 1898/C

018980940

Wheeled sprayer, 25 l

~~£ 254.00~~  
**£ 154.00**

- Dual function: spraying and foaming
- Painted steel tank
- Stainless steel nozzle
- Anti-twisting hose
- Tank pressure gauge
- Tank level indicator

#### Technical data:

- Tank capacity: 25
- Supply hose length: 5 m
- Maximum working pressure: 4-5 bar
- Nozzle length: 0.65 m
- Maximum tank pressure: 8 bar



### 3002

030020001

Creeper and seat

~~£ 118.00~~  
**£ 68.00**

- Steel frame
- PVC lining with upholstery
- Easily convertible into a creeper or a seat

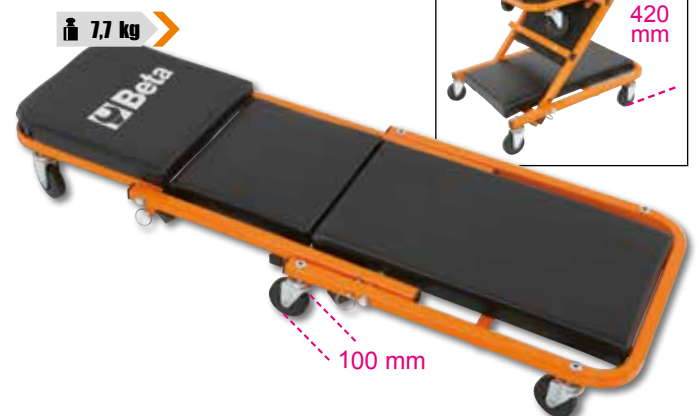

7,7 kg

# 3028 HYDRAULIC PRESS WITH MOVING PISTON



Hydraulic press



	kg		£
<b>3028 15</b>	57	030280015	<del>£ 1,084.00</del> <b>£ 615.00</b>
<b>3028 20</b>	98	030280020	<del>£ 1,575.00</del> <b>£ 889.00</b>
<b>3028 30</b>	132	030280030	<del>£ 2,195.00</del> <b>£ 1,229.00</b>
<b>3028 50</b>	241	030280050	<del>£ 3,840.00</del> <b>£ 2,170.00</b>

	3028 15	3028 20	3028 30	3028 50
Maximum capacity	15 t	20 t	30 t	50 t
Single speed pump	✓	✓	✓	✓
Moving piston	✓	✓	✓	✓
Hydraulic safety in case of overloading	✓	✓	✓	✓
Gauge	✓	✓	✓	✓
Set of V-shaped prisms	✓	✓	✓	✓
Hoist	X	X	X	✓

## 3028/KP 030280055

Kit of pin punches and plate for presses 3028

~~£ 136.50~~  
**£ 78.50**

Sizes of pin punches:

- Ø10X90mm
- Ø12X90mm
- Ø16X90mm
- Ø18X115mm
- Ø20X115mm
- Ø22X115mm
- Ø25X140mm
- Ø30X140mm



## 3027PR/N 030270410

Press supporting tool for removal/insertion of hubs, bearings and silent blocks

~~£ 283.00~~  
**£ 161.00**

Universal device allowing user to install/remove hubs, bearings and silent blocks into/from their housings by operating via a press, through a supporting base and dedicated accessories. Designed to adapt to irregular geometric shapes of hubs/king pins on which operator must work. Can be used with presses 3027N and 3028.

Technical data:

- Working range: min. 135 mm - max. 150 mm
- Dimensions: 250x202 mm
- Maximum load bearing capacity: 20 t



**3029/2T**

030290020

**Lowered hydraulic jack, 2 t, with 4 wheels**

~~£ 437.00~~  
**£ 249.00**

- Quick approach pedal
- Steel frame and nylon wheels
- Minimum height: 75 mm



H min-Max mm	L mm	L1 mm
75÷500	720	290



**3029L/2T**

030290120

**Long, lowered hydraulic jack, 2 t**

~~£ 587.00~~  
**£ 289.00**

Makes it possible to work on vehicles with a reduced height from the ground and internal lifting point.

- Controlled descent speed
- Quick approach pedal
- Nylon wheels



H min-Max mm	L mm	L1 mm
75÷520	930	295



**3033E/3T**

030330130

**Hydraulic jack, 3 t**

~~£ 488.00~~  
**£ 249.00**

- Controlled descent speed
- Nylon wheels



H min-Max mm	L mm	L1 mm
95÷515	700	370



**3030/2T**

030300020

**Lowered hydraulic car jack, 2 t with 6 wheels**

- Car jack can be easily handled on uneven, irregular floors
- Dual front tilting wheels made of plastic material (PTFE)
- Pedal allows easy approach

H min-Max mm	L mm	L1 mm
85÷520	860	400



**3029AL/1,5T**

030290015

**Aluminium hydraulic jack, 1.5 t**

~~£ 428.00~~  
**£ 188.00**

With a weight of no more than 15 kg and a capacity of 1.5 t, this tool means a perfect combination of performance and convenience, to allow you to deal with the most unexpected and critical situations: rescue operations, e.g. on race tracks, or emergency services.

H min-Max mm	L mm	L1 mm
76÷355	550	240



**PRACTICAL BAG INCLUDED IN THE PRICE!**

**3030H/2T** >>> > 030300220 <<<

**High-lift hydraulic jack, 2 t, with 6 wheels**

Makes it possible to work on vehicles that are high from the ground and have a long shock absorber travel

- Controlled descent speed
- Quick approach pedal
- Nylon wheels

~~£ 697.00~~  
**£ 395.00**

H min-Max mm	L mm	L1 mm
85÷780	1010	300



**2 t**

**3033/3T** >>> > 030330030 <<<

**Hydraulic jack, 3 t long version**

- Particularly suitable for use on commercial vehicles
- Polyamide wheels

~~£ 1,101.00~~  
**£ 629.00**

H min-Max mm	L mm	L1 mm
140÷520	1180	370



**3 t**

**3065/40-20T** >>> > 030650200 <<<

**Air hydraulic jack, 40/20 tons**

- Suitable for use on heavy vehicles
- Functional and easy to handle, for transportation on mobile repair shops as well
- Automatic piston return
- Two descent valves with under load speed control

~~£ 3,100.00~~  
**£ 1,735.00**

H min-Max mm	L mm	L1 mm
150÷300	525	300



**40-20 t**

**3067/60-15T** >>> > 030670120 <<<

**Air hydraulic jack, 60-30-15 t**

- Automatic piston return
- Two descent valves with under load speed control
- Supplied with two extensions, 70 and 120 mm long
- Power supply pressure: 8-10 bar
- Air consumption: 600 l/min

~~£ 4,570.00~~  
**£ 2,605.00**

H min-Max mm	L mm	L1 mm
120÷255	660	250



**60-30-15 t**

**3023**

030230050

Pit and under bridge jack with screw adjustment

~~£ 228.00~~  
**£ 130.00**

**MAXIMUM CARRYING CAPACITY: 350 KG**

H min-Max mm	Ø mm
1350÷2030	300



**3011T**

Hydraulic bottle jack



	C max kg	H min+max mm		£
<b>3011T 2</b>	2000	174÷369	030110020	<del>£ 93.00</del> <b>£ 48.90</b>
<b>3011T 3,5</b>	3000	170÷366	030110035	<del>£ 103.50</del> <b>£ 53.50</b>
<b>3011T 5</b>	6000	203÷467	030110050	<del>£ 116.50</del> <b>£ 63.00</b>
<b>3011T 10</b>	10000	220÷484	030110100	<del>£ 174.50</del> <b>£ 92.00</b>
<b>3011T 15</b>	15000	230÷497	030110150	<del>£ 213.00</del> <b>£ 116.00</b>
<b>3011T 20</b>	20000	245÷521	030110200	<del>£ 267.00</del> <b>£ 154.00</b>
<b>3011T 32</b>	32000	260÷420	030110320	<del>£ 278.00</del> <b>£ 163.00</b>
<b>3011T 50</b>	50000	280÷450	030110500	<del>£ 322.00</del> <b>£ 194.00</b>

**3010T**

Jack stands, pair

	C max kg	H min+max mm		£
<b>3010T 2</b>	2000	280÷425	030100002	<del>£ 103.50</del> <b>£ 57.00</b>
<b>3010T 3</b>	3000	285÷430	030100003	<del>£ 123.50</del> <b>£ 67.00</b>
<b>3010T 6</b>	6000	400÷580	030100006	<del>£ 179.00</del> <b>£ 96.50</b>
<b>3010T 10</b>	10000	471÷735	030100010	<del>£ 308.00</del> <b>£ 163.00</b>



3010T 2  
3010T 3  
3010T 6



**3010H**

Heavy-duty jack

	C max kg	H min+max mm	L x L1 mm	kg		£
<b>3010H631-T15</b>	15,000	445÷631	300x300	22,5	030100150	<del>£ 333.00</del> <b>£ 188.00</b>
<b>3010H1077-T15</b>	15,000	645÷1077	300x300	30	030100165	<del>£ 418.00</del> <b>£ 229.00</b>



**3010V**

Heavy-duty jack stands, screw adjustable

	C max kg	H min+max mm	L / L1 mm		£
<b>3010V600-T20</b>	20,000	410÷600	330x330	030100200	<del>£ 485.00</del> <b>£ 269.00</b>
<b>3010V1090-T20</b>	20,000	665÷1090	460x460	030100220	<del>£ 617.00</del> <b>£ 350.00</b>



**3006** > < 030060000

**Jack and positioner for tractor and excavator wheels**

- Max. capacity: 1,500 kg
- Min. wheel diameter: 1,000 mm
- Max. wheel diameter: 2,200 mm
- Max. wheel thickness: 800 mm

~~£ 1,875.00~~  
**£ 979.00**



**1,5 t**

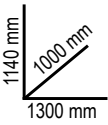

**30145AR** > < 030140360

**Folding engine stand**

- Easy to fold up, for significantly increased compactness
- Allows 360° rotation of engine or gear
- Provides unparalleled safety and stability during jobs

~~£ 1,468.00~~  
**£ 839.00**

**MAXIMUM CAPACITY: 450 KG**

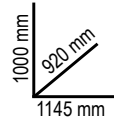

**360°**



**3024** >

**Folding hydraulic crane with dual effect pump**

- 5 loading positions
- With load limiting valve and chrome-plated stand
- Controlled descent speed
- Nylon wheels
- Maximum height: 2300 mm
- Working radius of arm: min. 960 mm – max. 1350 mm
- Operating unit can be rotated 200°



**3024 0.6**

**3024 1.0**

	3024 0.6	3024 1.0
Maximum capacity	600 kg	1000 kg
Loading positions	400-450-500-550-600 kg	600-700-800-900-1000 kg
Maximum height	2300 mm	2300 mm
Dimensions (LxHxPxP1)	1375x1540x370x942 mm	1450x1550x390x960 mm



	kg		£
<b>3024 0,6</b>	73	030240006	<del>£ 731.00</del> <b>£ 419.00</b>
<b>3024 1,0</b>	88	030240010	<del>£ 1,023.00</del> <b>£ 579.00</b>

**3025N/PF** > < 030250111

**Barrel handling pliers**



~~£ 493.00~~  
**£ 279.00**

**MAXIMUM CAPACITY: 300 KG**



## 3022

### Hydraulic pit and under bridge jack

Compact and versatile, the hydraulic pit jack makes it easier to install and remove transmission, chassis and other supports. With an adjustable lifting height up to 1,975 mm and a maximum capacity of 300 kg, it is ideal for jobs in the garage. The continuously variable locking mechanism and the pivoting castors make it easy to handle it.

	C max kg	H min+max mm	Pedal pump		£
<b>3022 0,3</b>	300	1140 ÷ 1975	✓	030220003	<del>£ 416.00</del> <b>£ 229.00</b>
<b>3022 0,6</b>	600	1140 ÷ 1975	✓	030220006	<del>£ 501.00</del> <b>£ 279.00</b>
<b>3022 1,0</b>	1000	1167 ÷ 2007	✓	030220010	<del>£ 615.00</del> <b>£ 329.00</b>



## 3026

### Hydraulic pit and under bridge jack

	Maximum capacity	Pedal pump	H min+max mm	Load limiting valve	kg		£
<b>3026 0,3</b>	300	✓	1120 ÷ 1970 mm	✓	24,7	030260003	<del>£ 719.00</del> <b>£ 395.00</b>
<b>3026 0,5</b>	500	✓	1140 ÷ 1990 mm	✓	31	030260005	<del>£ 855.00</del> <b>£ 439.00</b>
<b>3026 1,0</b>	1000	✓	1140 ÷ 1990 mm	✓	37,8	030260010	<del>£ 1,032.00</del> <b>£ 515.00</b>



## 3026/SP

030260505

### Universal transmission support



~~£ 708.00~~  
**£ 339.00**

- Allows one operator to disassemble and reassemble any transmissions of cars, commercial vehicles and off-roaders quickly and safely
- Suitable for stands with diameter: 25-30-35-45 mm
- Max. capacity: 150 kg
- Height: 250 mm



## 3026 2P/1,5-0,6

030260015

### Hydraulic pit and under bridge jack, two-stage

~~£ 2,460.00~~  
**£ 1,409.00**

- Dual speed piston ascent
- Double chrome-plated stand
- Load limiting valve
- Controlled descent speed
- Pivoting wheels
- Release knob
- Maximum first-stage capacity: 1,500 kg
- Maximum second-stage capacity: 600 kg



**Robur**

Lifting web slings, two layers with reinforced eyes high-tenacity polyester (PES) belt EN 1492-1

- Lifting web slings
- Two layers with reinforced eyes
- High-tenacity polyester (PES) belt

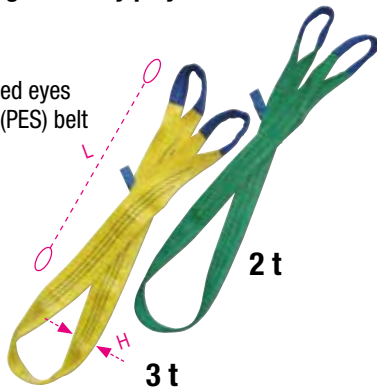

	L m	H mm	WLL kg		£
8153 1-T2	1	60	2	081530010	<del>£ 8.95</del> £ 5.90
8153 2-T2	2	60	2	081530020	<del>£ 13.90</del> £ 8.50
8153 3-T2	3	60	2	081530030	<del>£ 18.80</del> £ 11.00
8153 4-T2	4	60	2	081530040	<del>£ 23.20</del> £ 14.50
8156 2-T3	2	90	3	081560020	<del>£ 20.70</del> £ 12.50
8156 3-T3	3	90	3	081560030	<del>£ 29.80</del> £ 18.00
8156 4-T3	4	90	3	081560040	<del>£ 35.50</del> £ 21.90
8156 6-T3	6	90	3	081560060	<del>£ 50.50</del> £ 30.00

**8181-8182**

Bag with set of ratchet tie-downs high-tenacity polyester belt, single hooks



EN 12195-2



	L m	LC kg	PCS x bag		£
8181 6/B4	6	1000	4	081810916	<del>£ 71.00</del> £ 38.00
8182 8,5/B2	8,5	2000	2	081821885	<del>£ 62.50</del> £ 33.00



**8190**

Ratchet load binder with 2 hooks Grade 8

EN12195/3

	Ø mm	LC daN	Ø mm	LC daN		£
<b>8190 8</b>	8	4000	X	X	081900008	<del>£ 52.00</del> £ 28.50
<b>8190 10</b>	10	6300	8	4000	081900010	<del>£ 78.50</del> £ 42.50



**8145VX**

Hand chain blocks, compact

- Technical data:
- Safety factor: 4
  - Serial identification tag

- Available certificates:
- Manufacturer's Certificate
  - CE Declaration of Conformity
  - Test Report UNI EN10204 type 2.2
  - Technical Product Specifications

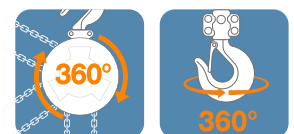
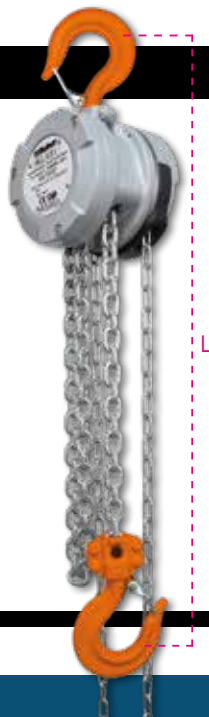

TUV CERTIFICATION EN 13157

	WLL kg	L m	kg		£
<b>8145VX 125</b>	125	3	2,5	081450001	<del>£ 279.00</del> £ 147.00
<b>8145VX 500</b>	500	3	4,5	081450005	<del>£ 327.00</del> £ 171.00

**NEW**

**3050/600**

**Electro-hydraulic motorcycle jack, 600 kg**

- Electrical, mechanical and hydraulic safety devices
- Integrated electro-hydraulic unit: 230V - 50 Hz
- Hydraulic pump
- Controlled downward speed
- Safety fuses for protection in case of cable cuts
- Control push button panel
- CE-certified, TÜV-approved



~~£ 5,570.00~~  
**£ 2,979.00**

kg  
**600**

198 kg



H min-Max mm	L mm
180÷1300	2100

Ral 2011	Ral 7016	Ral 3000
030500201	030500202	030500203

**3040C**

030400002

**Rear motorcycle stand, adjustable**

- Includes V-shaped sliders, pair
- Includes L-shaped sliders, pair

~~£ 82.00~~  
**£ 47.50**

**3041C**

030410002

**Front motorcycle stand, adjustable**

- Includes roller sliders, pair
- Includes cone-shaped sliders, pair

~~£ 77.00~~  
**£ 44.50**



- Matt black lacquer
- 4 thermoplastic rubber wheels

**3043C**

030430002

**Motorcycle stand with left single arm**

- Optional pin

~~£ 101.00~~  
**£ 57.00**



**2002/B27 SBK**

020020927

**Travelling kit for motorbikers**

Quantity/Description	Beta N.
8 Double open end wrenches 6x7-8x9-10x11-12x13-14x15-16x17-18x19-20x22 mm	55
9 Offset hexagon key wrenches 1,5-2-2,5-3-4-5-6-8-10 mm	96BPC/SC9
3 Evox screwdrivers for slotted head screws 3,5x100-5,5x150-6,5x150 mm	1201E
2 Evox screwdrivers for cross head Phillips® screws 4,5x80 - 6x100 mm	1202E
1 Multipurpose tool complete with bits and sheath	1778MT
1 LED inspection torch 133 mm	1833 XS/2
1 Instant glue for structural joints 5 gr	9851
1 PVC electrical tape sp.0,15 mm / 19 mm x 25 m	BMESB1925NE
50 Nylon cable ties 4,8x300 mm	BMN3048
1 Roll-up tool wallet made of durable polyester, empty	2002/BV42

~~£ 304.00~~  
**£ 132.00**

595X540 mm



2,8 kg

**3910**

039100010

**E-Bike lift**

- Maximum height of central movement support: 135 cm
- Built-in wheel truing stand
- Innovative thru-axle locking system
- Supplied with adapter sockets for most forks
- Supplied with fork connection adapter without thru-axle
- Fully foldable and transportable

~~£ 3,678.00~~  
**£ 1,895.00**

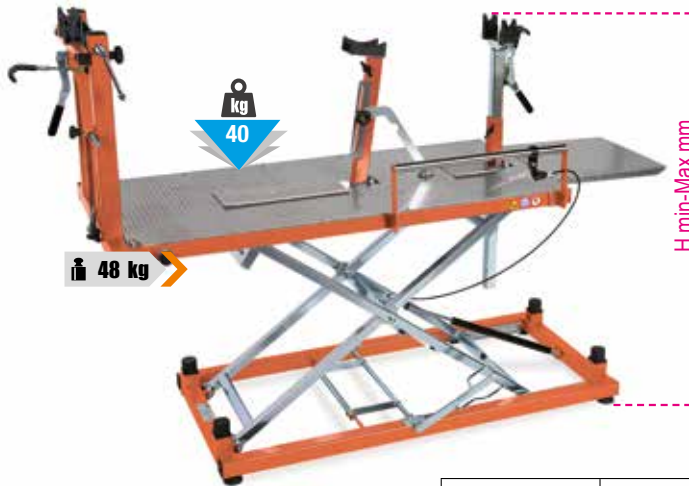

H min-Max mm	L mm
600÷1350	80

**3919MME**

039190010

**Workshop single-sided electric clamp for bicycle maintenance**

- Clamp that can be rotated up to 180° and rubber jaws
- Load capacity: 35 kg
- Adjustable height
- Can be fixed to floor, or with optional stand

~~£ 4,648.00~~  
**£ 2,459.00**

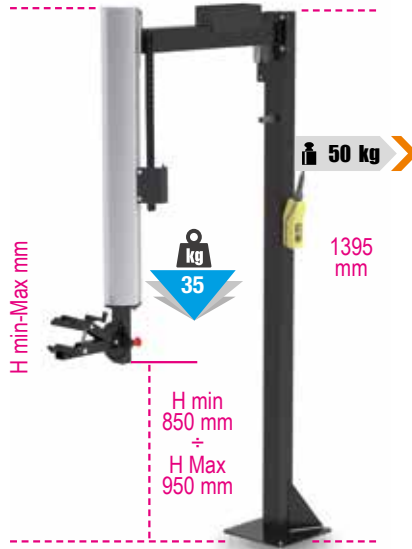

H min-Max mm
2640÷2740



**NEW**

**3918MML**

039180010

**Single-sided clamp, lightweight, foldable**

- Single-sided clamp, lightweight
- Clamp can be rotated 360°
- Carrying capacity: 15 kg
- Maximum clamp height: 150 cm
- Stand weight: 4.5 kg

~~£ 304.00~~  
**£ 151.00**

4.5 kg



**3919MME/P**

039190011

**Self-supporting stand**

For single-sided clamp item 3919MME

~~£ 709.00~~  
**£ 385.00**

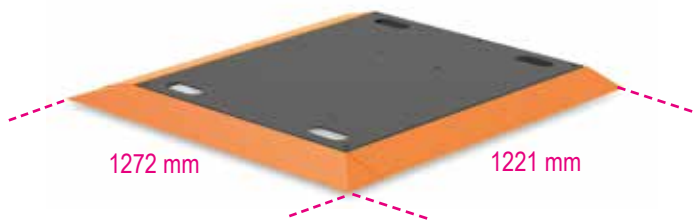

**NEW**

**605BC/15**

006050015

**Click-type torque wrench with reversible ratchet, for right-hand tightening, compact, made from aluminium, torque accuracy: ± 4%**

The smallest torque wrench of Beta's range: compact and easy to use, it provides an ideal combination of convenience and simplicity within reach.

UNI EN ISO 6789 **14"** **723**

~~£ 228.50~~  
**£ 120.00**



Nm	kgfm	lbf.ft	■	L (mm)	
3÷15	0,3÷1,5	26÷133	1/4"	175	0,1

**COMPACT:  
NO MORE THAN 17.5 CM**



**NEW**

# KIT AUTOMOTIVE

4 kits, 4 comprehensive solutions for your work.  
Discover the new automotive kits designed for every job.

## 3033/KVA-1

030330901

Automotive kit with hydraulic jack item 3033E/3T, C51 trolley, swivel creeper seat 2251NA and reversible impact wrench item 1927P/K3 with 3 impact sockets

**C51** 12

**3033E/3T** 67

**1927P/K3** 77 + 57

**2251NA**

**£ 1,435.00**  
**£ 569.00**

**SAVE £ 137.00**  
Compared to purchases of loose products

**NEW**

## 3033/KVA-2

030330902

Automotive kit with hydraulic jack item 3033E/3T, creeper/seat 3002 and reversible impact wrench item 1927P/K3 with 3 impact sockets.

**3002** 65

**3033E/3T** 67

**1927P/K3** 77 + 57

**£ 1,100.00**  
**£ 409.00**

**SAVE £ 113.00**  
Compared to purchases of loose products

**NEW**

NEW

# TYRE KIT

## 19270LS/KVA

019271091

Tyre kit with Oil-less impact wrench item 19270LS, torque wrench item 666/20, tyre inflator 1949GPA and sockets item 720LC/C3

19270LS



666/20



720LC/C3



~~£ 1,147.00~~  
**£ 529.00**

1949GPA



**SAVE £ 78.40**

Compared to purchases of loose products

NEW

## 1927C/KVP

019271082

Tyre kit with item 1927C torque wrench, item 666/20 and sockets item 720LC/C3, 720MRC, 720FRD, 720RNG

1927C



666/20



720LC/C3



720MRC



720FRD



720RNG



~~£ 613.00~~  
**£ 259.00**



**SAVE £ 85.60**

Compared to purchases of loose products

NEW

# THE REVOLUTIONARY IMPACT WRENCH THAT DOES NOT REQUIRE LUBRICATION



2,5 kg

## 19270LS

019270010

**OIL-LESS reversible impact wrench, body made from aluminium alloy**

The OIL-LESS impact wrench stands out for high torque transmission – that is, 1750 Nm –, which makes it ideal for any application.

- No lubrication required
- Double hammer impulse device



£ 711.00  
**£ 379.00**



12"



Free speed	8.000 rpm
Max. torque	1.750 Nm
Bolt capacity	Cl 8.8 M24●36 mm
Bolt capacity	Cl 12.9 M20●30 mm
Air inlet	1/4" GAS
Operating pressure	6,2 bar
Internal hose size (Ø)	10 mm
Mean air consumption	198 l/min

# PATENT PENDING

## 1927P

019270008

**Reversible impact wrench**

- Double hammer impulse device
- Lightweight and well-balanced for enhanced ease of use
- Reversible lever
- Three power adjustable screwing positions
- Exhaust through handle
- Vibration-damping handle

**1750 Nm**



2 kg

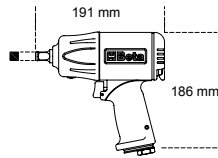

12"



£ 439.00  
**£ 188.00**

Free speed	rpm	7.500
Impulse device		Double hammer
Max. torque	Nm	1750
Bolt capacity	Cl 8.8	M24●36 mm
Bolt capacity	Cl 12.9	M20●30 mm
Air inlet	GAS	1/4"
Operating pressure	bar	6,2
Internal hose size (Ø)	mm	10
Mean air consumption	l/min	290

## 1927E

019270005

**Reversible impact wrench, made from composite material**

- Double hammer impulse device
- Reverse control knob
- Three power adjustable screwing positions
- Exhaust through handle
- Vibration-damping handle



£ 136.50  
**£ 75.50**

12"



2,4 kg

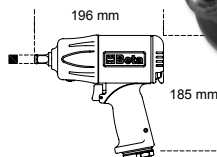

Free speed	rpm	7.000
Impulse device		Double hammer
Max. torque	Nm	750
Bolt capacity	Cl 8.8	M22●36 mm
Bolt capacity	Cl 12.9	M18●30 mm
Air inlet	GAS	1/4"
Operating pressure	bar	6,2
Internal hose size (Ø)	mm	10
Mean air consumption	l/min	140

## 1927C

019270006

**Reversible impact wrench, made from composite material**

- Double hammer impulse device
- Lightweight and well-balanced, for enhanced ease of use
- Reverse control lever
- Three power adjustable screwing positions
- Exhaust through handle
- Vibration-damping handle



£ 228.50  
**£ 125.00**

12"



2,1 kg

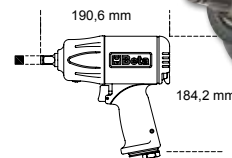

Free speed	rpm	9.000
Impulse device		Double hammer
Max. torque	Nm	950
Bolt capacity	Cl 8.8	M22●34 mm
Bolt capacity	Cl 12.9	M18●27 mm
Air inlet	GAS	1/4"
Operating pressure	bar	6,2
Internal hose size (Ø)	mm	10
Mean air consumption	l/min	125

1927XM

019270030

Compact reversible impact wrench



£ 273.00  
£ 144.00

- Single hammer impulse device
- Amazingly compact and powerful
- One-hand reverse button
- Three power adjustable screwing positions
- Exhaust through handle
- Balancing hook

12"

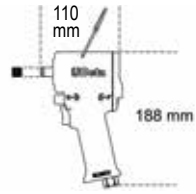

ULTRA COMPACT

Free speed	rpm	10.000
Impulse device		Single hammer
Max. torque	Nm	770
Bolt capacity	Cl 8.8	M22●34 mm
Bolt capacity	Cl 12.9	M18●27 mm
Air inlet	GAS	1/4"
Operating pressure	bar	6,2
Internal hose size (Ø)	mm	10
Mean air consumption	l/min	122

1,3 kg



1927XM/K5

019270129

Assortment of 1 compact reversible impact wrench and 5 impact sockets, in plastic case



£ 336.00  
£ 171.00

720 17-19-21-22-24 mm

12"

2,8 kg

307x206x86 mm



1927G

019270050

Compact reversible impact wrench

- Single hammer impulse device
- Aluminium motor housing with composite handle
- One-handed reverse control
- Three power adjustable screwing positions
- Exhaust through handle
- **Head motor with direct rotation transmission to output drive, resulting in improved body balancing and increased handiness**



£ 427.00  
£ 188.00

12"

1,2 kg

Free speed	rpm	8.500
Max. torque	Nm	325
Bolt capacity	Cl 8.8	M16●24 mm
Bolt capacity	Cl 12.9	M14●21 mm
Air inlet	GAS	1/4"
Operating pressure	bar	6,2
Internal hose size (Ø)	mm	10
Mean air consumption	l/min	113

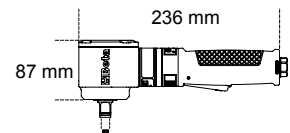

1928XM

019280030

Compact reversible impact wrench

- Double hammer impulse device
- Amazingly compact and powerful
- One-hand reverse button
- Three power adjustable screwing positions
- Exhaust through handle



£ 583.00  
£ 329.00

3/4"

ULTRA COMPACT AND POWERFUL

1600 Nm

Free speed	rpm	4.800
Impulse device		Double hammer
Max. torque	Nm	1600
Bolt capacity	Cl 8.8	M27●41 mm
Bolt capacity	Cl 12.9	M24●36 mm
Air inlet	GAS	3/8"
Operating pressure	bar	6,2
Internal hose size (Ø)	mm	10
Mean air consumption	l/min	175



2,9 kg

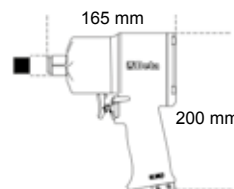

## 1928DA

019280022

### Reversible impact wrench

- Double hammer impulse device
- Sturdy and compact; high torque
- Reversible lever
- Three power adjustable positions
- Exhaust through handle
- Slip-proof ergonomic handle



£ 843.00  
£ 379.00

3/4"

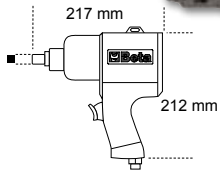

Free speed	rpm	5.000
Impulse device		Double hammer
Max. torque	Nm	1695
Bolt capacity	Cl 8.8	M30●46 mm
Bolt capacity	Cl 12.9	M27●41 mm
Air inlet	GAS	3/8"
Operating pressure	bar	6,2
Internal hose size (Ø)	mm	10
Mean air consumption	l/min	210

4.3 kg

## 1928P

019280006

### Reversible impact wrench, made from composite material

- Double hammer impulse device
- Lightweight and well-balanced for enhanced ease of use
- Reversible lever
- Three power adjustable screwing positions
- Exhaust through handle
- Vibration-damping handle



£ 1,161.00  
£ 529.00

3/4"

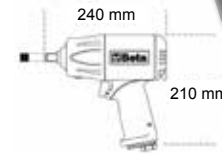

Free speed	rpm	5.000
Impulse device		Double hammer
Max. torque	Nm	2100
Bolt capacity	Cl 8.8	M30●46 mm
Bolt capacity	Cl 12.9	M27●41 mm
Air inlet	GAS	3/8"
Operating pressure	bar	6,2
Internal hose size (Ø)	mm	10
Mean air consumption	l/min	221

3.7 kg

2100 Nm

## 1930LH

019300030

### Reversible impact wrench

- Double hammer impulse device
- 210 mm (8.3") long anvil
- New 70-degree angled handle design to relieve stress and fatigue on the operator's wrists
- Auxiliary side handle
- 3 power adjustable screwing/unscrewing positions
- Lower exhaust
- Excellent weight/power ratio



£ 1,300.00  
£ 719.00

1"

Free speed	rpm	6.000
Impulse device		Double hammer
Max. torque	Nm	2441
Bolt capacity	Cl 8.8	M36●55 mm
Bolt capacity	Cl 12.9	M30●46 mm

Air inlet	GAS	1/2"
Operating pressure	bar	6,2
Internal hose size (Ø)	mm	13
Mean air consumption	l/min	280



7.1 kg

## 1930PA

019300032

### Reversible impact wrench

- Double hammer impulse device
- Auxiliary handle
- Reversible lever
- Three power adjustable screwing/unscrewing positions
- Exhaust through handle



£ 1,260.00  
£ 680.00

1"

Free speed	rpm	3.500
Impulse device		Double hammer
Max. torque	Nm	2445
Bolt capacity	Cl 8.8	M36●55 mm
Bolt capacity	Cl 12.9	M30●46 mm
Air inlet	GAS	1/2"
Operating pressure	bar	6,2
Internal hose size (Ø)	mm	13
Mean air consumption	l/min	350



9.6 kg

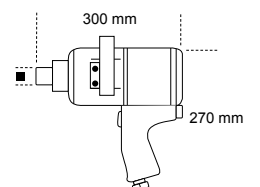

**720ME/C8**

007200525

Set of 8 impact socket drivers for hexagon screws, in metal case

0 5-6-8-10-12-14-17-19 mm

270x120x45 mm



~~£ 161.00~~  
**£ 87.00**



**720TX/C6**

007200483

Set of 6 impact socket drivers for Torx® head screws, in metal case

T30-T40-T45-T50-T55-T60



275x120x65 mm



**720/C24**

007200904

Set of 24 impact sockets, 1/2" female drive, phosphatized, in metal case



420x185x60 mm



	N°	Description
	720	15 10-12-13-14-15-16-17-18 19-21-22-24-27-30-32 mm
	720L	6 13-17-19-21-22-24 mm
	720LC	3 17-19-21 mm

**720/C12**

007200912

Set of 12 impact sockets, in metal case

10-11-12-13-14-17-19-22-24-27-30-32 mm



195x80x55 mm



**728/C10**

007280910

Set of 10 impact sockets, in metal case

17-19-22-24-27-30-32-36-41-46 mm



275x120x65 mm



~~£ 348.00~~  
**£ 188.00**

~~£ 192.00~~  
**£ 106.00**

### Reversible air impact ratchets



- Double rocking dog impulse device
- Easy tightening: The impact mechanism system eliminates wrist twisting at end of screwing and shortens operating time
- Compact and powerful: maximum torque is significantly higher than maximum torque as achieved with a conventional ratchet
- Ergonomic rubber handle

#### 1922P1 >> << 019220006

68 Nm

~~£ 270.00~~  
**£ 154.00**



Free speed	rpm	700
Maximum torque	Nm	68
Bolt capacity	Cl 8.8	M10●16 mm
Bolt capacity	Cl 12.9	M8●13 mm
Air inlet	GAS	1/4"
Operating pressure	btor	6.2
Internal hose size (Ø)	mm	10
Mean air consumption	l/min	88

#### 1922P3 >> << 019220013

136 Nm

~~£ 426.00~~  
**£ 239.00**



Free speed	rpm	600
Maximum torque	Nm	136
Bolt capacity	Cl 8.8	M12●18 mm
Bolt capacity	Cl 12.9	M10●16 mm
Air inlet	GAS	1/4"
Operating pressure	btor	6.2
Internal hose size (Ø)	mm	10
Mean air consumption	l/min	113

**HIGH TORQUE  
WITHOUT  
AFFECTING WRIST**

#### 1937 >> << 019370001

### Roto-orbital palm sander, lubrication free, made from composite material

- No lubrication required
- Extremely compact and easy to handle
- Orbit diameter: 5 mm
- 6-hole Velcro pad
- Continuous motor speed adjustment
- Nonslip, soft material handle
- Designed for connection to suction systems with swivel fittings
- Revolving exhaust



**Ø Orbit 5 mm**

~~£ 467.00~~  
**£ 188.00**

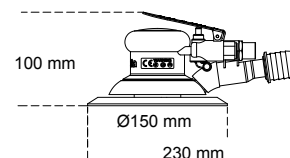

Free speed	rpm	12.000
Maximum torque	kW	0,18
Bolt capacity	mm	150
Bolt capacity		5/16"-24
Air inlet	GAS	1/4"
Operating pressure	btor	6.2
Internal hose size (Ø)	mm	10
Mean air consumption	l/min	170

#### 1942A >> << 019420000

### Air saw

- Powerful and handy
- Designed for cutting bodies, exhaust pipes and silencers, aluminium and plastic
- Complete with rubber handle, PVC exhaust pipe and air-feeding hose
- Rear exhaust

~~£ 329.00~~  
**£ 185.00**

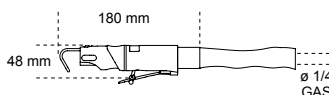

Strokes per minute		10.000
Stroke length	mm	10
Air inlet	GAS	1/4"
Operating pressure	btor	6.2
Internal hose size (Ø)	mm	8
Mean air consumption	l/min	75

# RENEGADE



## UNCONVENTIONAL STYLE

EN ISO 20345 2022



### 7340VA

RENEGADE mesh fabric shoe, highly breathable, with ATOP lacing

~~£ 170.00~~  
**£ 93.50**



495 g

S1PS FO SR HRO

Sizes available: from 37 to 48

from 073400537 to 073400548

### 7340G

RENEGADE mesh fabric shoe, highly breathable, with traditional lacing

~~£ 138.00~~  
**£ 78.90**



495 g

S1PS FO SR HRO

Sizes available: from 37 to 48

from 0734000637 to 073400648

### 7341V

RENEGADE woven fabric, hard-wearing and breathable, green details

~~£ 145.50~~  
**£ 80.50**



495 g

S1PS FO SR HRO

Sizes available: from 37 to 48

from 073410537 to 073410548

### 7341Y

RENEGADE woven fabric shoe, hard-wearing and breathable, yellow details

~~£ 145.50~~  
**£ 80.50**



495 g

S1PS FO SR HRO

Sizes available: from 37 to 48

from 073410637 to 073410648

### 7342N

RENEGADE microfibre shoe, water-repellent

~~£ 154.50~~  
**£ 87.50**



500 g

S3S FO SR HRO

Sizes available: from 37 to 48

from 073420537 to 073420548

### 7343N

RENEGADE microfibre ankle shoe, water-repellent

~~£ 168.00~~  
**£ 93.50**



510 g

S3S FO SR HRO

Sizes available: from 37 to 48

from 073430537 to 073430548

## FitEvolution



## PATENTED SYSTEM FIT4YOU

## 7272V

FitEvolution woven fabric shoe,  
hard-wearing and highly breathable~~£ 147.00~~  
£ 82.50

i 550 g &gt;

S1 PS FO SR ESD

Sizes available: from 37 to 48

📄 from 072720137 to 072720148

## 7270Y

FitEvolution mesh fabric shoe,  
highly breathable~~£ 147.00~~  
£ 82.50

i 550 g &gt;

S1 PS FO SR ESD

Sizes available: from 37 to 48

📄 from 072700137 to 072700148

## 7271V

FitEvolution suede shoe,  
perforated~~£ 147.00~~  
£ 82.50

i 550 g &gt;

S1 PS FO SR ESD

Sizes available: from 37 to 48

📄 from 072710137 to 072710148

## 7273G

FitEvolution nubuck shoe,  
water-repellent~~£ 151.00~~  
£ 84.50

i 590 g &gt;

S3 S FO SR ESD

Sizes available: from 37 to 48

📄 from 072730137 to 072730148

## 7274G

FitEvolution nubuck ankle shoe,  
water-repellent~~£ 156.00~~  
£ 87.50

i 650 g &gt;

S3 S FO SR ESD

Sizes available: from 37 to 48

📄 from 072740237 to 072740248

## 7275N

FitEvolution microfibre shoe,  
water-repellent~~£ 151.00~~  
£ 84.50

i 590 g &gt;

S3 S FO SR ESD

Sizes available: from 37 to 48

📄 from 072750237 to 072750248

**Beta**  
O-Gravity

METAL FREE CE

**7352B**

O-Gravity mesh fabric shoe, highly breathable, with TPU inserts  
• Stretch slip-on collar

~~£ 131.00~~  
**£ 74.00**

EN ISO 20345 : 2022 + T01 : 2024



450 g  
S1PL FO SR HRO

Sizes available: from 38 to 48  
from 073520138 to 073520148

**7352G**

O-Gravity ultralightweight mesh fabric shoe, highly breathable  
• Traditional lacing

~~£ 136.00~~  
**£ 76.50**

EN ISO 20345 : 2011



450 g  
S1P HRO SRC ESD



Sizes available: from 38 to 48  
from 073520338 to 073520348

**ACTIVE**

METAL FREE CE

**7317NA**

Suede shoe, perforated, with microfibre reinforcement in heel area

~~£ 71.50~~  
**£ 41.90**

EN ISO 20345 : 2022 + T01 : 2024



S1PL FO SR

Sizes available: from 35 to 48  
from 073170135 to 073170148

**7320NA**

Nubuck shoe, water-repellent, with anti-abrasion reinforcement in toe cap area

~~£ 75.00~~  
**£ 43.50**

EN ISO 20345 : 2022 + T01 : 2024



S3L FO SR

Sizes available: from 35 to 48  
from 073200535 to 073200548

**BASIC PLUS** **NEW**

T11 METAL FREE EN ISO 20345 : 2022 + T01 : 2024 CE

**7200BP**

Suede shoe with highly breathable mesh inserts

~~£ 52.00~~  
**£ 30.00**



S1PS FO SR

Sizes available: from 35 to 48  
from 072000635 to 072000648

**7203BP**

Leather ankle shoe, smooth-finished, water-repellent, with quick opening system

~~£ 59.50~~  
**£ 34.90**



S3S FO SR RS

Sizes available: from 35 to 48  
from 072030635 to 072030648

## 7569NG



3-in-1 jacket, with outer jacket and removable inner vest:

~~£ 168.00~~  
£ 90.50

- **Outer shell** in 100% polyester with waterproof, windproof, breathable TPU membrane (resistance to water columns up to 8,000 mm - breathability 3,000 mvp)
- **Inner vest** in 100% nylon and 100% polyester padding, 100 g/m<sup>2</sup>, with detachable hood
- **Black with anthracite grey inserts**



XS	S	M	L	XL	2XL	3XL
075690000	075690001	075690002	075690003	075690004	075690005	075690006

## 7565NG

Sweatshirt, long-zipped

~~£ 61.50~~  
£ 34.90

- 60% cotton, 40% polyester, 280 g/m<sup>2</sup>
- Stretch sleeve bottoms and waist
- **Black with anthracite grey inserts**



XS	S	M	L	XL	2XL	3XL
075650400	075650401	075650402	075650403	075650404	075650405	075650406

## 7570NG



Stretch work trousers, multipocket style

~~£ 67.00~~  
£ 33.90

- 94% polyester, 6% spandex, 140 g/m<sup>2</sup>,
- Reinforced pockets, stretch waist
- **Anthracite grey, with black inserts**
- Slim fit



XS   46	S   48	M   50	L   52	XL   54	2XL   56	3XL   58
075700000	075700001	075700002	075700003	075700004	075700005	075700006

## 7571NG



Stretch work Bermuda shorts, multipocket style

~~£ 57.50~~  
£ 27.90

- 94% polyester, 6% spandex, 140 g/m<sup>2</sup>,
- Reinforced pockets, stretch waist
- **Anthracite grey, with black inserts**
- Slim fit



XS   46	S   48	M   50	L   52	XL   54	2XL   56	3XL   58
075710000	075710001	075710002	075710003	075710004	075710005	075710006

# NEW TOP LINE

HIGH PERFORMANCE



**7342N**  
Renegade 82

7982N

079820000

Curved visor cap,  
black

~~£ 9.65~~  
£ 5.50



7643G

Sweatshirt, short-zipped

- 80% cotton, 20% polyester, 280 g/m<sup>2</sup>
- Anthracite/light grey

~~£ 47.50~~  
£ 26.50



	XS	S	M	L	XL	2XL	3XL
	076430000	076430001	076430002	076430003	076430004	076430005	076430006

7642G

Crew-neck sweatshirt  
with black inserts on shoulders  
and fluorescent green detail

- 60% cotton, 40% polyester, 240 g/m<sup>2</sup>

~~£ 31.50~~  
£ 17.90



	XS	S	M	L	XL	2XL	3XL
	076420000	076420001	076420002	076420003	076420004	076420005	076420006

7821SG

Stretch work Bermuda shorts,  
multipocket style, lightweight

- 9% cotton, 61% polyester, in mechanical stretch ripstop fabric, 170 g/m<sup>2</sup>
- Grey

~~£ 47.50~~  
£ 26.50



	XS   46	S   48	M   50	L   52	XL   54	2XL   56	3XL   58
	078210100	078210101	078210102	078210103	078210104	078210105	078210106

7820SG

Stretch work trousers,  
multipocket style,  
lightweight

- 9% cotton, 61% polyester, in mechanical stretch ripstop fabric, 170 g/m<sup>2</sup>
- Grey

~~£ 60.50~~  
£ 34.50



	XS   46	S   48	M   50	L   52	XL   54	2XL   56	3XL   58
	078200100	078200101	078200102	078200103	078200104	078200105	078200106



7340VA  
Renegade 82

## 7548D

T-shirt with graffiti style print

- 100% cotton, 150 g/m<sup>2</sup>, black



~~£ 14.20~~  
£ 8.50

	XS	S	M	L	XL	2XL	3XL
075480600	075480601	075480602	075480603	075480604	075480605	075480606	

**NEW**

## 7548T

T-shirt with modern print

- 100% cotton, 150 g/m<sup>2</sup>, black



~~£ 14.20~~  
£ 8.50

	XS	S	M	L	XL	2XL	3XL
075480700	075480701	075480702	075480703	075480704	075480705	075480706	

**NEW**

## 7550

Technical work t-shirt, with 37.5<sup>®</sup> technology

- 70% 37.5<sup>®</sup> polyester
- 30% reversible polyester mesh
- 120 g/m<sup>2</sup>

**COMFORTABLE AND BREATHABLE**

37.5<sup>®</sup> TECHNOLOGY  
HYPOALLERGENIC,  
SKIN-FRIENDLY TECHNOLOGY



~~£ 39.00~~  
£ 22.50

	XS	S	M	L	XL	2XL	3XL
7550G	075500400	075500401	075500402	075500403	075500404	075500405	075500406
7550N	075500500	075500501	075500502	075500503	075500504	075500505	075500506

## 7935MG

Work overalls

- 97% cotton, 3% stretch fabric, 220 g/m<sup>2</sup>
- Grey

*Cotton*



~~£ 102.00~~  
£ 56.00

	XS   46	S   48	M   50	L   52	XL   54	2XL   56	3XL   58
079350400	079350401	079350402	079350403	079350404	079350405	079350406	

## 7930MG

Work trousers, multipocket style

- 97% cotton, 3% stretch fabric, 220 g/m<sup>2</sup>
- Stretch waistband
- Grey

*Cotton*



~~£ 58.00~~  
£ 31.90

	XS   46	S   48	M   50	L   52	XL   54	2XL   56	3XL   58
079300400	079300401	079300402	079300403	079300404	079300405	079300406	

# LINEA EASY

- 65% polyester, 35% cotton; 180 g/m<sup>2</sup>
- T/C ripstop insets and knee pads
- Strap "Oxford" snap loop

## 7860

Work trousers, lightweight in T/C twill, 180 g/m<sup>2</sup>

~~£ 51.50~~  
**£ 27.50**

LIGHT 

	XS   46	S   48	M   50	L   52	XL   54	2XL   56	3XL   58	4XL   60	5XL   62
<b>7860B</b>	078600700	078600701	078600702	078600703	078600704	078600705	078600706	078600707	078600708
<b>7860G</b>	078600800	078600801	078600802	078600803	078600804	078600805	078600806	078600807	078600808
<b>7900G</b>	079000800	079000801	079000802	079000803	079000804	079000805	079000806	079000807	079000808

## 7900G

Work trousers  
New design - Improved fit

~~£ 57.00~~  
**£ 30.00**





Grey

Blue



Grey

## 7865G

Work overalls, lightweight in T/C twill, 180 g/m<sup>2</sup>

~~£ 82.00~~  
**£ 45.50**

LIGHT 

	XS   46	S   48	M   50	L   52	XL   54	2XL   56	3XL   58	4XL   60	5XL   62
<b>7865G</b>	078650800	078650801	078650802	078650803	078650804	078650805	078650806	078650807	078650808
<b>7905G</b>	079050800	079050801	079050802	079050803	079050804	079050805	079050806	079050807	079050808

## 7905G

Work overalls New design - Improved fit

~~£ 89.50~~  
**£ 47.90**





Grey

## 7863G

Work bib and brace overalls, lightweight New design - Improved fit

~~£ 63.00~~  
**£ 35.90**

LIGHT 

	XS   46	S   48	M   50	L   52	XL   54	2XL   56	3XL   58	4XL   60	5XL   62
<b>7863G</b>	078630800	078630801	078630802	078630803	078630804	078630805	078630806	078630807	078630808
<b>7903G</b>	079030800	079030801	079030802	079030803	079030804	079030805	079030806	079030807	079030808

## 7903G

Work bib and brace overalls New design - Improved fit

~~£ 71.50~~  
**£ 38.50**



## 7861

Work bermuda shorts, lightweight, 220 g

~~£ 43.00~~  
**£ 23.50**

 LIGHT

	XS   46	S   48	M   50	L   52	XL   54	2XL   56	3XL   58	4XL   60	5XL   62
<b>7861B</b>	078610700	078610701	078610702	078610703	078610704	078610705	078610706	078610707	078610708
<b>7861G</b>	078610800	078610801	078610802	078610803	078610804	078610805	078610806	078610807	078610808



Blue

Grey

### 9526MC

095260020

Capsule espresso coffee machine

~~£ 238.00~~  
**£ 138.00**

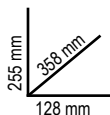

### 9563G

095630050

Office armchairs, for guests

~~£ 258.00~~  
**£ 126.00**

- Back height: 60 cm
- Seat dimensions: 45 cm x 51 cm
- Overall chair height: 110-120 cm
- Base: 28 cm (leg length) x 50-60 cm (height)
- Maximum weight capacity: 120 kg



### 9566K

095660500

Furnishing set of 1 table and 3 vertically adjustable stools

~~£ 386.00~~  
**£ 229.00**



### 9574

Work gloves, with stretch-elastic cuffs, reinforced thumbs and index fingers, made from touchscreen capable synthetic leather

~~£ 39.00~~  
**£ 18.50**



	PACKAGING	M	L	XL	2XL
9574B		095740102	095740103	095740104	095740105
95740		095740202	095740203	095740204	095740205

### 9577R

Work overalls with a racing-inspired style, for workers searching for a perfect combination of style and convenience



~~£ 151.00~~  
**£ 67.00**

**CONVENIENCE**

The 4-WAY STRETCH fabric provides unique comfort for every movement.

**STYLE**

The accurate details as well as the colours and inspiration from the racing world result in a captivating, trendy garment.



### 9526F

095260005

Mini fridge, energy efficiency class F, capacity 65 l, black

~~£ 548.00~~  
**£ 329.00**



### 9594

095940051

Clock complete with thermometer and hygrometer, 26 cm in diameter

~~£ 31.50~~  
**£ 18.00**



PACKAGING	S   48	M   50	L   52	XL   54	2XL   56	3XL   58
	095770151	095770152	095770153	095770154	095770155	095770156



# 2025 MOT02 WORLD CHAMPIONSHIP

CELESTINO VIETTI

ALONSO LÓPEZ



Beta Tools (UK) Limited | Unit D - Horton Enterprise Park  
Hortonwood 50, Telford | Shropshire, TF1 7GZ  
Sales: Tel. (01952) 677977

[www.beta-tools.com/uk](http://www.beta-tools.com/uk) | [sales@beta-tools.com](mailto:sales@beta-tools.com)