



3027N 20

CE

- Capacidade máxima: 20 t
- Bomba manual de 2 velocidades
- Pistão móvel
- Suporte cromado
- Retorno automático do pistão
- Dispositivo de segurança contra sobrecarga hidráulica
- Medidor
- Conjunto de prismas em forma de V incluído

 130 kg

	art.	H mm				
030270102	3027N 20	1870	920	580	600	130

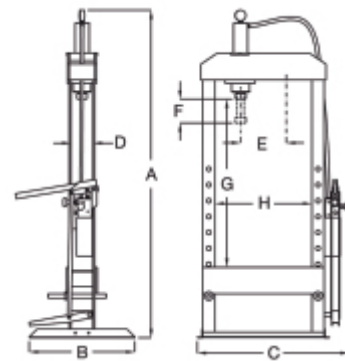

3027N 20	
A	1870
B	600
C	920
D	125
E	310
F	150
G	1000
H	580