



3027N 50
Hydraulische pers met bewegende zuiger en takel

CE

- Maximale capaciteit: 50 t
- Manuele pomp met 2 versnellingen
- Verschuifbare cilinder
- verchromde stand
- Automatische terugtrekken van de plunjer
- Hydraulisch veiligheidssysteem in geval van overbelasting
- Manometer
- Set van V-blokken inbegrepen
- Takel van staalkabel voor het tillen van werkblad

 350 kg

	art.	H				
030270105	3027N 50	2100	1350	790	750	350

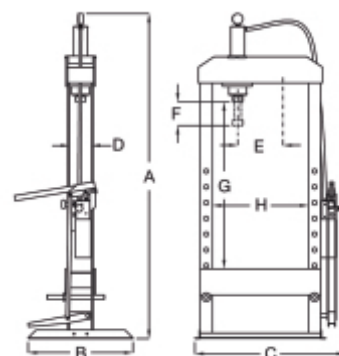
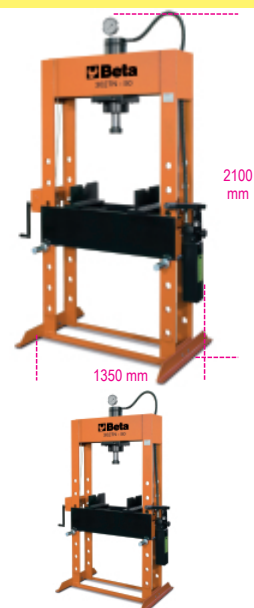

3027N 50	
A	2100
B	750
C	1350
D	230
E	480
F	165
G	1000
H	790